



Valves for Power Generation

Engineered Solutions for the
Power Generation Industry

MOGAS[®]
SEVERE SERVICE BALL VALVES

Valve Selection Guide

Table of Contents

Model	Bore (inches)	End Size (inches)	Class	Valve Information	Body Mat'l.	End Connection ¹				In Stock	Page
						SW	BW	RFF	CL		
RSVP-UK	0.38	1/2 – 3/4	ASME 600 / 900 / 1500 Limited Class	<ul style="list-style-type: none"> Lightweight Uni-Body Design with Mounting Bracket Uni-Directional Sealing 	F22 A105 F91	●	●			●	10
RSVP-UC RSVP-UF RSVP-UL	0.63 1.00 1.30	3/4 – 2-1/2	ASME 600 / 900 / 1500 Limited Class	<ul style="list-style-type: none"> Vents, Drains Forged Uni-Body Design Uni-Directional Sealing 	F22 A105 F91	●	●			●	12
RSVP-UM	1.50	2, 2-1/2	ASME 600 / 900 / 1500 Limited Class	<ul style="list-style-type: none"> Designed to meet TDP-1 1998 (Hot Reheat) Forged Uni-body Design Uni-Directional Sealing 	F22 A105 F91	●	●				12
RSVP-UC RSVP-UF RSVP-UL	0.63 1.00 1.30	3/4 – 2-1/2	ASME 3100 Limited Class	<ul style="list-style-type: none"> Vents, Drains Forged Uni-Body Design Uni-Directional Sealing 	F22 A105 F91	●	●			●	14
RSVP-UC RSVP-UF	0.63 1.00	3/4 – 2-1/2	ASME 4500 Limited Class	<ul style="list-style-type: none"> Vents, Drains Forged Uni-Body Design Uni-Directional Sealing 	F22 F91	●	●			●	16
GEN-X	Full Bore 2.00 1.87	2	ASME 600 / 900 / 1500 Limited Class	<ul style="list-style-type: none"> Designed to meet TDP-1 1998 (Cold Reheat) 2-Piece Cast Body 2 inch Full Bore 	WC9 WCC C12A	●				●	18
SC-3 PIECE	2.00	2 – 6	ASME 2500	<ul style="list-style-type: none"> Boiler Feedwater Heater, Recirculation Block, Attenuator Spray Block In-line Repairable, 3-Piece Forged Construction Standard 2 inch Bore 	F22		●			●	20
ISOLATOR	Full Bore	2 – 8	ASME 150 / 300	<ul style="list-style-type: none"> Ash Slurries Coal Slurries Bottom Ash 	CF8M (316SS)			●		●	22
C-SERIES	Full, Reduced, Custom	1/2 – 30	ASME 150 – 4500	<ul style="list-style-type: none"> Tight Isolation 2-Piece or 3-Piece Body Construction Uni-Directional / Bi-Directional Sealing 	All materials	●	●	●	●		24
PORV	1.30 1.60 1.81 2.00 2.125	Varies	ASME 1500 / 2500 / 4500	<ul style="list-style-type: none"> Power Operated Relief Valve ASME "V" Stamp Complete with Automation Package Proprietary Coating 	F22 F91		●	●			26
SD	Custom Bore	Per Specification	ASME 4500 Special Class	<ul style="list-style-type: none"> Main Steam Drain, Turbine Bypass Custom Built, 3-Piece Design Unidirectional Sealing 	F22	●					28

¹ Custom end connections available on all models, upon request.

Available End Connections

Socket Weld (SW)

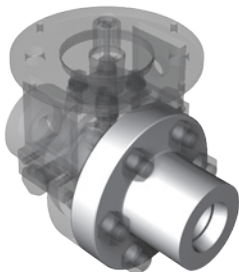

Butt Weld (BW)

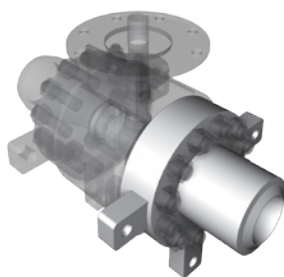

Raised-Face Flange (RFF)

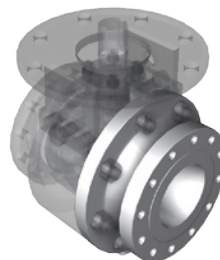

Clamped (CL)

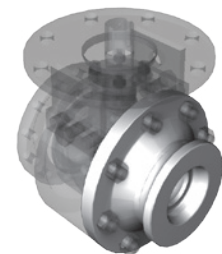

Actuation

All MOGAS ball valves are easily automated per customer actuator specifications.

Industry Codes & Standards

The following industry codes and standards are referenced in the manufacturing of MOGAS valves:
ASTM, CRN, DIN, ATEX, FCI, ISA, ISO, NBBI, PED, GOST-R, TUV, TA-Luft



MOGAS Valve Installations

Typical Fossil Fueled Power Plant

Water/Steam Flow Loop

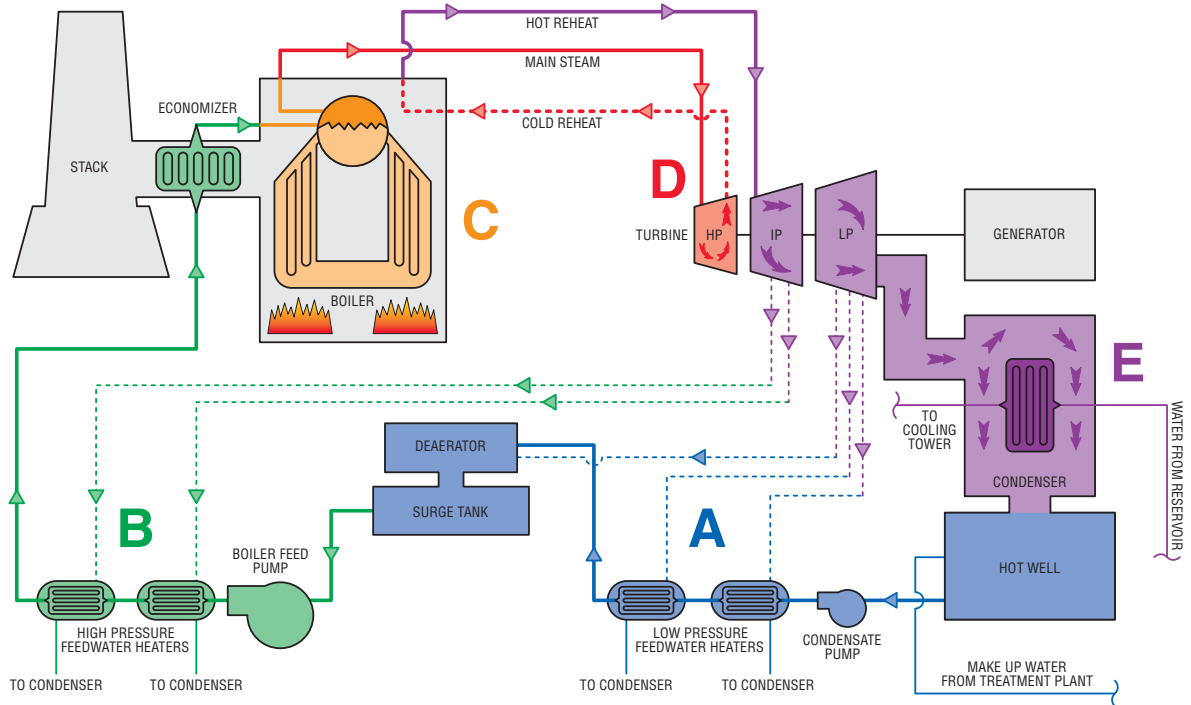

A Condensate System

- Deaerator Vent / Instrument Isolation
- Isolation Valves on Bypass Lines
- Extraction Steam Drain / Orifice Isolation
- Feedwater Heater Drain / Vent
- Shell Side Instrument Isolation

B HP Feedwater

- BFP Discharge Isolation
- BFP Shell or Case Drain
- BFP Minimum Flow Isolation
- BFP Warming Line Isolation / Drain
- Reheat / Superheat Isolation
- Feedwater Heater Isolation / Bypass
- Bypass Valves
- Shell Side Vent / Instrument Isolation
- Tube Side Drain / Instrument Isolation
- Economizer Drain

C Boiler System

- Drum Blowdown Root Valve / Isolation Vents
- Drum Instrument Isolation
- Sight-Glass Isolation / Drain
- Water Wall Drain / Vent / Instrument Isolation
- Tandem Blowdown
- Mass Boiler Blowdown
- Primary Superheat Drain / Vent / Instrument Isolation
- Secondary Superheat Drain / Vent / Instrument Isolation
- Reheat Drain / Vent / Instrument Isolation
- Superheat Spray Isolation
- Superheater Spray Automated Blocking
- Reheater Spray Isolation Blocking

D HP Turbine Steam Supply and Extraction Systems

- Supply & Extraction Systems
- Main Steam Drain / Root Drain
- Main Steam Before & After Seat Drain / Root Drain
- Main Steam Lead Drain / Root Drains
- Turbine Bypass Isolation
- Bypass Valves

E IP & LP Turbine Steam Supply and Extraction Systems

- Supply Extraction Systems
- Hot Reheat Drain / Root Drain
- Hot Reheat at the CRV Drain / Root Drain
- IP & LP Turbine Extraction Drain / Orifice Isolation

Auxiliary Systems

Sootblower Piping System

- Sootblowing Header Isolation / Blocking
- Sootblower Regulator Automated Isolation
- Blocking Valves after the Control Valves
- Sootblower System Crossover Header Isolation
- Sootblower Bank Isolation
- Individual Sootblower Isolation
- Air Heater Sootblower Steam Supply Line Shutoff
- Sootblower Thermal Drains / Bypass

HP & LP Steam Supply System to the BFP Turbine

- Main Steam Supply Isolation Valve
- HP BFP Steam Supply Drain / Root Drain
- HP BFP Below & Above Seat Drain / Root Drain
- Isolation Valves on the Bypass Lines
- Extraction Steam Supply to LP BFP Turbine Drains
- LP BFP Below & Above Seat Drain

Inerting Steam System

- Inert Steam Inlet to Pulverizer Blocking / Automated Isolation
- Steam Supply to Inerting System Pressure Regulator Isolation
- Extraction Steam Supply Line to the Inerting Steam Header Drain
- Isolation Valves on the Bypass Lines
- Inerting System Steam Header Thermal Drain

MOGAS Valve Installations

Typical Combined Cycle Power Plant

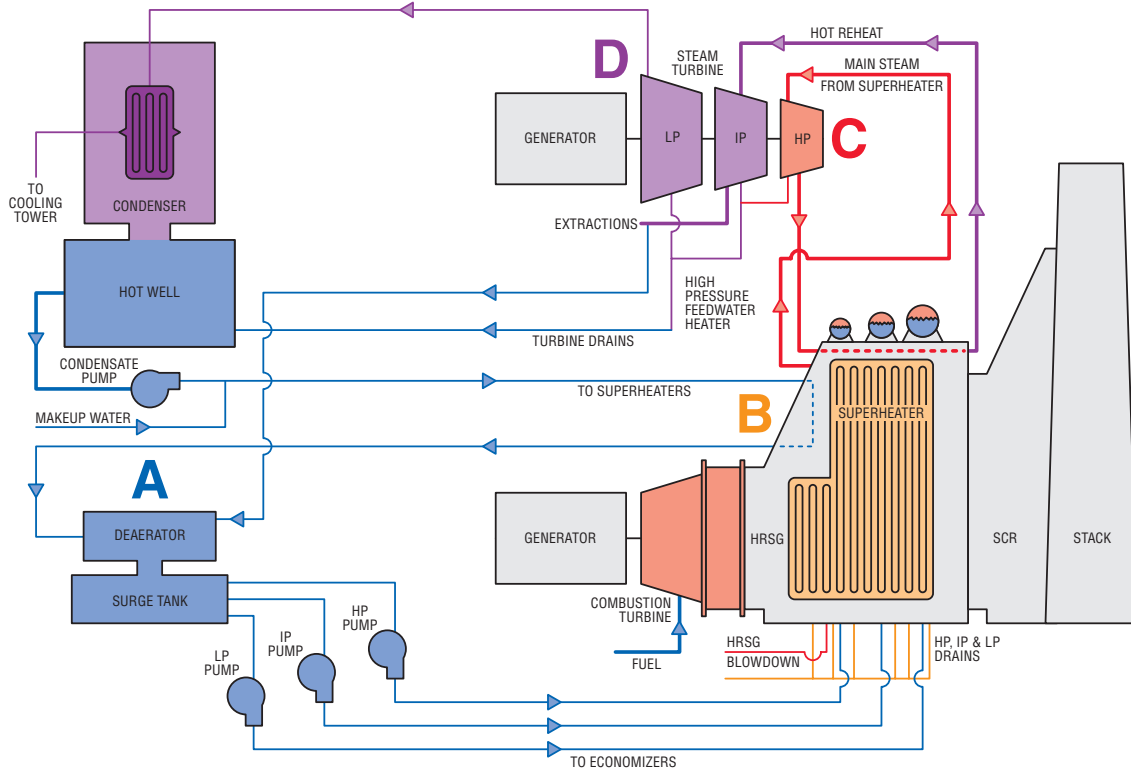

A Feedwater System

- Deaerator Vent / Instrument Isolation
- Isolation Valves on Bypass Lines
- Extraction Steam Drain / Orifice Isolation

B HRSG

- BFP Discharge Isolation
- BFP Shell or Case Drain
- BFP Minimum Flow Isolation
- BFP Warming Line Isolation / Drain
- Reheat / Superheat Spray Root Isolation
- Feedwater Heater Isolation / Bypass
- Bypass Valves
- Shell Side Vent / Instrument Isolation
- Tube Side Drain / Instrument Isolation
- Drum Blowdown Root Valve / Isolation Vents
- Drum Instrument Isolation
- Sight-Glass Isolation / Drain
- Water Wall Drain / Vent / Instrument Isolation
- Tandem Blowdown
- Mass Boiler Blowdown
- Primary Superheat Drain / Vent / Instrument Isolation
- Secondary Superheat Drain / Vent / Instrument Isolation
- Reheat Drain / Vent / Instrument Isolation
- Superheat Spray Isolation
- Superheater Spray Automated Blocking
- Reheater Spray Isolation Blocking
- LP Section HRSG Tube Drains
- IP Section HRSG Tube Drains
- HP Section HRSG Tube Drains
- Automated Bottom Blowdown
- SCR Steam Induction Isolation

C HP Turbine Steam Supply and Extraction Systems

- Supply & Extraction Systems
- Main Steam Drain / Root Drain
- Main Steam Before & After Seat Drain / Root Drain
- Main Steam Lead Drain / Root Drain
- Turbine Bypass Isolation
- Bypass Valves

D IP & LP Turbine Steam Supply and Extraction Systems

- Supply Extraction Systems
- Hot Reheat Drain / Root Drain
- Hot Reheat at the CRV Drain / Root Drain
- IP & LP Turbine Extraction Drain / Orifice Isolation

Setting the Standard

Engineered Solutions to Maximize Performance and Safety

Field Proven Experience

Through years of field experience, working with major power producers and a sophisticated performance analysis procedure, MOGAS has developed a product line dedicated to absolute isolation of critical equipment, dependable on/off operation for drains and vents, as well as longer valve life for increased run-time.

MOGAS provides its advanced technology to the power industry with the RSVP, PORV, C-Series, SC-3 Piece, SD and GEN-X lines to handle high-temperatures, high-pressures, high-cycling, thermal shock and abrasive media.

Our portfolio of valve solutions lets you choose the design, trims, materials, and coatings that best fit your severe service application for power generation.

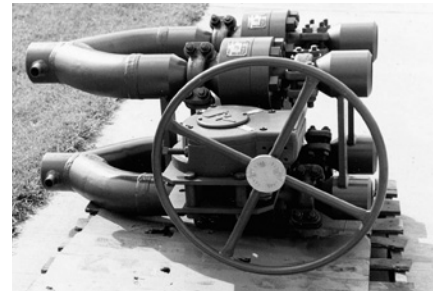

Unique custom-built valve configuration consists of four, 2-inch ASME 1500 Class valves with operating conditions of 300°F at 2600 psi (149°C at 179 bar). The valves were linked for a specific sequence in order to synchronize open/close of bypass lines.

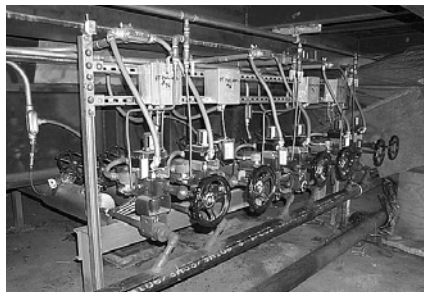

These high and intermediate pressure automated RSVP-UC valves have been in successful operation for 8 years. Installed at a cogeneration gas fired plant on the east coast, these valves have fail-safe actuators with jack-screw override.

Certifications

MOGAS severe service ball valves are certified **PED compliant** for the European Union. When used as Power Operated Relief Valves, MOGAS PORV valves may be stamped with the **ASME "V" Stamp**, to ensure they have been designed, manufactured, inspected and tested to meet the requirements of ASME Code Section I.

Testing

- Leakage Rates per MSS SP-61
- Shell Tests performed at 1.5 x Max Cold Working Pressure
- Seat Closure Tests performed at 1.1 x Max Cold Working Pressure

Customer Service

MOGAS field service technicians are available 24 hours a day, year round, worldwide. MOGAS technical advisors will assist with on-site installation, training, and maintenance walkdowns.

Warranty

MOGAS is pleased to offer MOGAS ball valves with a product warranty that is superior to other ball valve manufacturers. More detailed information is available in the standard terms and conditions.

RSVP valves manufactured by MOGAS for Power Generation Services are warranted against defects of material and/or workmanship for a period of **four years** from the date shipped when these products are properly installed in accordance with the operations and maintenance manual and used within the service and pressure range for which they were manufactured.



These four, 2-inch GEN-X MOGAS ball valves are handling Cold Reheat Isolation in a coal-fired plant.

MOGAS Design

Solves Common Valve Concerns In Power Plants

Ball Valves Outperform and Outlast the Alternatives

- Gate and globe valves are multi-turn, torque seated valves that must seal against line pressure.
The MOGAS RSVP is a quarter-turn, position seated ball valve that utilizes pressure assisted sealing.
- Since drain valves remain open during start-up and shut-down, gate and globe valves can experience rapid erosion and wear due to primary sealing components being in the flow path of high pressure steam.
The MOGAS RSVP offers a straight-through bore path and protects the sealing components from the flow path.

RSVP Pressure Assisted Sealing

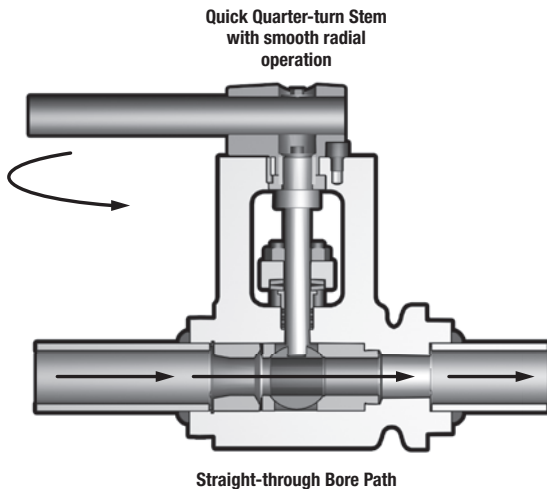

Globe Torque Seated

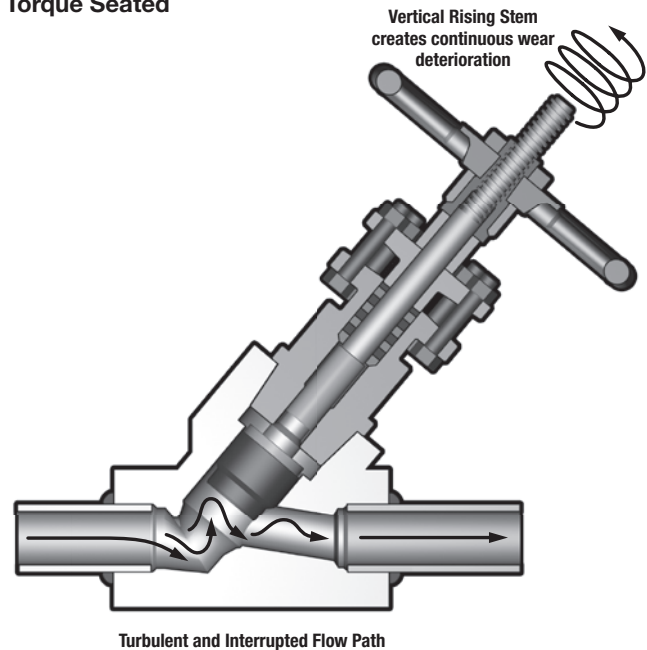

Prevents Leaks to Atmosphere

The quick quarter-turn, radial operation of the MOGAS ball valve greatly reduces wear and friction in the packing area. By contrast, the multi-turn rising stem of a globe valve often pulls destructive high pressure steam and pipe scale up through the packing interior diameter damaging the packing material. Additionally, the MOGAS RSVP offers live loading as a standard. The five-ring packing set includes two anti-extrusion rings and three expanded graphite rings with an adjustable, two-piece packing gland.



Continual stem leaks from globe valves allows plant efficiency to decrease and maintenance costs to rise.



The hazardous effects of high pressure wire draw and the breakdown of torque seated sealing can create safety concerns and jeopardize the effectiveness of power generation.

Resolves Seat Erosion

The MOGAS ball valve protects the main sealing surface by keeping the seat out of the flow path when the valve is in the open and closed position. The only time the seats are exposed to flow is during cycling, which is brief due to the quick, quarter-turn operation of the valve. In contrast, Y-pattern globe valves have a turbulent flow path and place primary sealing components in the flow path leading to plug and seat erosion. By protecting your sealing surfaces, you maintain tighter shutoff and extend the service life of the valve.



As shown in this competitor's valve, if seats are not protected from constant exposure to high pressure steam, destructive erosion can occur.

Eliminates Valve Seizure

MOGAS ball valves withstand thermal shock even when subjected to sudden swings from minimum to maximum design temperatures or vice versa. The sealing surfaces are of the same materials ensuring the same rate of expansion due to sudden heat.

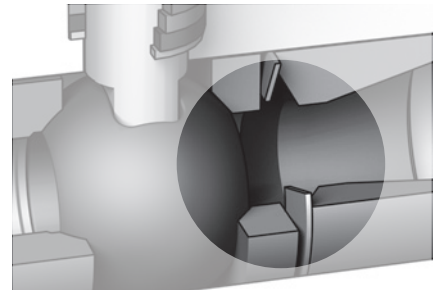

The seat pocket is designed to allow for thermal shocks while maintaining tight sealing. Zero leakage is created by the Bellville spring pushing the ball into the downstream seat.

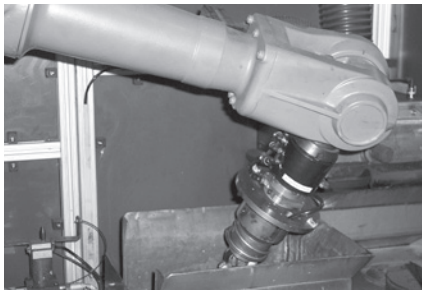

All MOGAS balls and seats are mate-lapped to ensure precise sealing. Both hand lapping or robotic lapping (as shown above) are used to provide full contact between ball and seats.

Maintains Absolute Shutoff

The MOGAS ball valve is a floating ball design, which incorporates a Bellville spring behind the upstream seat that provides a mechanical force to push the ball into the downstream seat, thus creating a tight seal. In addition to this mechanical spring force, the floating design enables line pressure to assist in the sealing of the ball and seat, versus the needed torque required in globe valves. Furthermore, the MOGAS ball and seat sealing areas are precision lapped to achieve 100% contact over the entire seat surface, eliminating areas for leaks to develop.



Using the latest technology, this seat is receiving a coating. MOGAS coatings are specially chosen to handle the operating conditions of each application.

Avoids Galled Seats

Our experience leads us to choose materials with higher hardness, producing less chance of galling while increasing wear resistance. The MOGAS seating surface has a 62 HRC hardness that ensures protection from scratches and particulate impregnation that can lead to galling and the development of dangerous leak paths. Through continual metallurgical R&D efforts, MOGAS has developed technology to overcome many galling problems.

Innovation by Design

Improved RSVP

- 1 Lockout feature** integrated into handle adaptor, which accommodates customer's lockout device in open and closed positions.
- 2 Mechanical precision stop** for open position with locking set screws for adjustment. Actuator torque is transmitted directly through the stem adaptor to the stop. Stop ensures correct ball orientation and prevents misalignment on automated valve.
- 3 Integral mounting flange** prevents disassembly. Integral flange provides rigid mounting of actuation with no loosening or shifting between bracket and body.
- 4 Double-keyed stem** for reliable and more convenient adaptation of gears, pneumatics, hydraulics and motor operators.

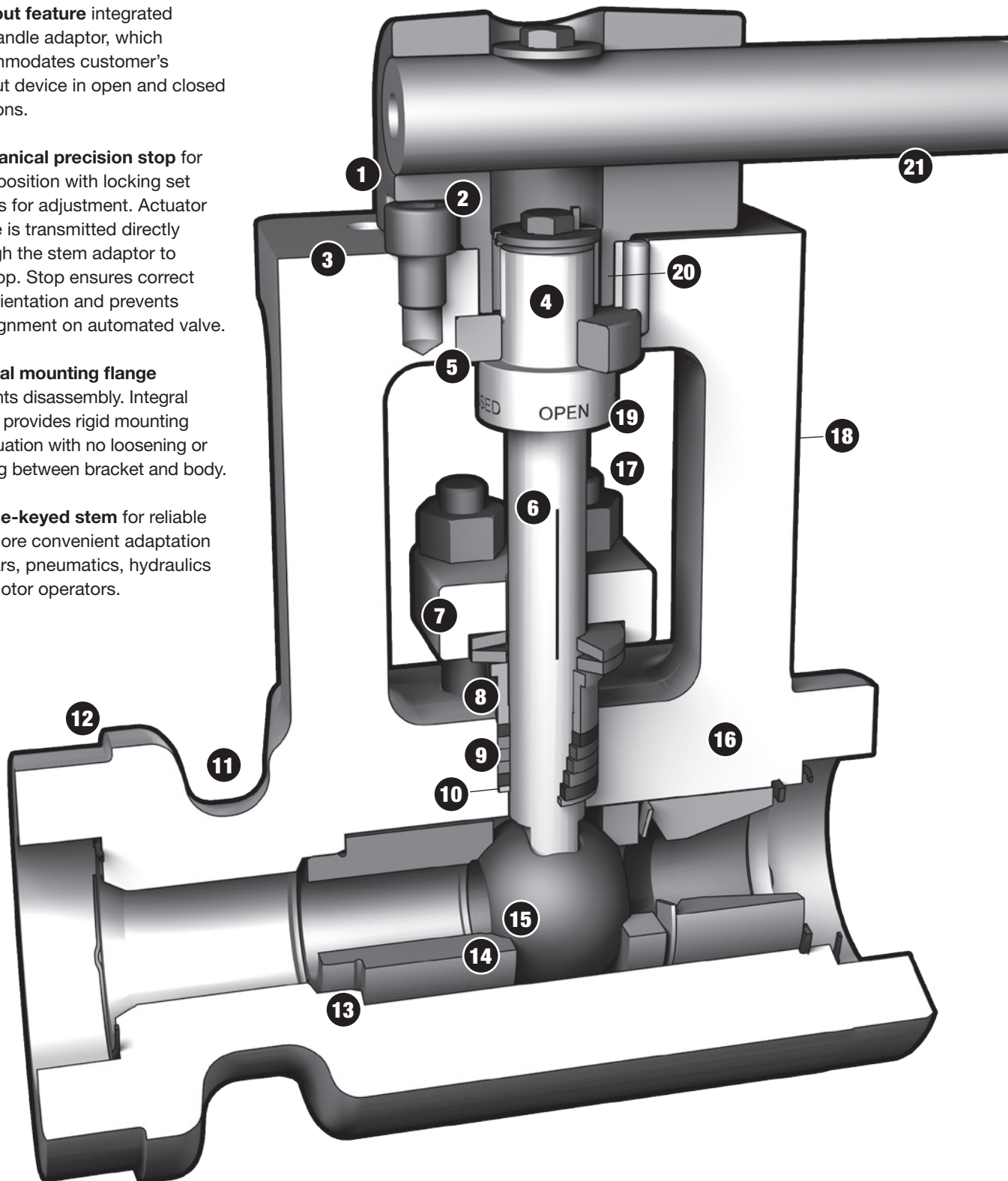

Operating convenience...Sealing performance...Dependability.



- 5 Stem bushing** prevents stem blowout and aligns stem radially. **Coated** for wear resistance.
- 6 Single scribe line** on gland aligns with open or closed scribe line on stem to indicate proper ball and seat alignment and correct ball direction.
- 7 Two-piece gland** with concentric live loading has ample allowance for adjustments while maintaining sealing integrity. The gland flange, thruster studs and nuts are 316SS for corrosion resistance, while the thruster is coated for wear resistance. The live load springs are Inconel.
- 8 The gland thruster** is machined for a continuous tight connection with the stem and packing box to prevent packing extrusion and maintain stem alignment in operation.
- 9 Deep stuffing box** with proven .125 inch cross-section Chesteron™ packing and dual anti-extrusion rings that provide reliable sealing and longevity.
- 10 Metal anti-extrusion ring** minimizes packing extrusion.
- 11 Integral vented body design** protects the valve during Post Weld Heat Treatment (PWHT).
- 12 Stop** on downstream end indicates limit for heat ribbons used for stress relief. **Raised diameter** acts as radiant fin for heat dissipation during Post Weld Heat Treatment (PWHT.)
- 13 Proven press-fit seat design.** ASME 1500 Limited Class, 410SS / Chromium Carbide ASME 3100 / 4500 Limited Class, Inconel 718 / Chromium Carbide
- 14 Oversized bore** at seat face allows for rapid thermal expansion without exposing seat face to process flow. **Wider seat faces** increase seal longevity.
- 15 Mate-lapped ball and seat** of same material and coating to match thermal expansion rates.
- 16 Forged body** for reliable pressure containment.
- 17 Increased clearance** and visibility around packing nuts provides easier access for adjustment. Gland components can be raised for installation of skive-cut packing rings. **Greater length** between stem bushing and packing box bearing surfaces for more precise stem alignment.
- 18 Nameplate** permanently attached to mounting flange leg, visible above insulation. Nameplate location indicates high-pressure end in the closed position.
- 19 Stem with integrated thrust bearing** prevents disassembly in-line and supports greater axial load. Reliable wear life. **Coated** stem for wear and gall resistance. Marked with open and close to clearly show operating position. Stem does not extend above the face of the mounting flange.
- 20 Adaptor is supported** in the bore of the mounting flange for the length engaged with the stem. This is provided by MOGAS.
- 21 Handle can be repositioned** to any location along its length. Can be applied as a T-handle or reversed to downstream for limited clearance. Handle length is 24 inch maximum in standard pipe outside diameters.

Features Not Shown

Flow arrow forged into mounting flange visible above insulation.

Complies with **ASME B16.34** requirements.

Socketweld ends per **ASME B16.11.**

Blank configuration for butt weld and customer end connections.

Actuator mounting per **MSS SP-101.**

Metallurgically bonded coating as standard on ASME 3100 and 4500 Class valves. Optional on ASME 1500 Class valves.

Patented design.

RSVP-UK

ASME 600 / 900 / 1500 Limited Class

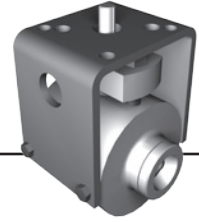

Applications

Boiler drains
Feedwater drains
Steam drum vents
Isolation valve for bypass lines
Economizer header drains

End Connections

Socketweld
Buttweld
Flanged¹

Sizes

1/2 to 3/4 inch

¹ Available Upon Request

Features

Ball and Seats

- Mate-lapped for 100% contact
- Ensures absolute shutoff
- Corrosion resistant
- Seats are protected from flow in open / closed position

Stem & Packing Arrangement

- Live Loading
- Quarter-turn non-rising stem does not deteriorate packing
- Extensive stuffing box
- Dual anti-extrusion rings keep packing in place

Mechanical Precision Stop

- Prevents turning ball 180°
- Eliminates misalignment

Rigid Mounting Bracket

- Designed to support actuator in any position

Seat Spring

- Assisted by line pressure, provides a constant mechanical force on ball against seat to maintain seal

Bill of Materials

Item No.	Description	Material
1	Ball	410SS / CC Coated
2	Seat	410SS / CC Coated
3	Spring	Inconel 718
4	Body	A182 F22 A105 A182 F91
5	Gasket	316 / Grafoil
6	Stem	A638 Gr660
7	Live Loading	Inconel 718
8	Gland Thruster	316 Nitrided
9	Gland Flange	410SS
10	Stem Packing	Expanded Graphite
11	Anti-Extrusion Rings	Braided Graphite w/ Inconel Wires
12	Retaining Ring	A638-660

- **Standard four-year warranty; one-year warranty on high-cycle applications (1 cycle per day, 365 days per year)**

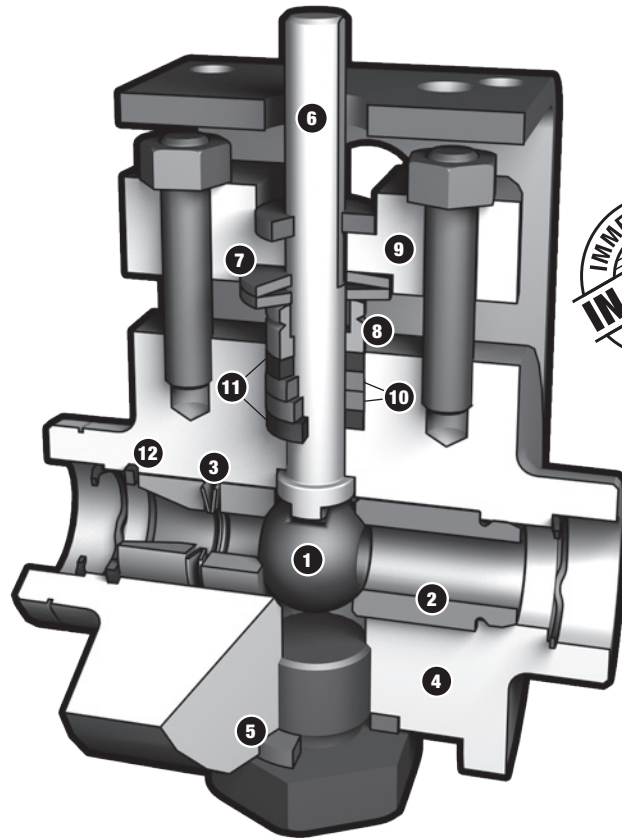

RSVP-UK

Small in Size — Large in Performance

Designed for Small, but Critical Applications

In power generation systems there are several severe service applications which require a small bore and/or light weight drain, vent or isolation valve. Many of the standard commodity choices such as globes cannot handle absolute tight shutoff for these small bore, high pressure, and high temperature installations, and normal metal-seated ball valves weigh too much. MOGAS offers a real workhorse for the small, but critical applications.

Dimensions (in)							
Model	Bore	A	B	C	D	E	Weight
RSVP-UK	0.38	1.85	3.75	6.44	3.47	N/A	7 lb

Dimensions (mm)							
Model	Bore	A	B	C	D	E	Weight
RSVP-UK	10	47	95	164	88	N/A	3 Kg

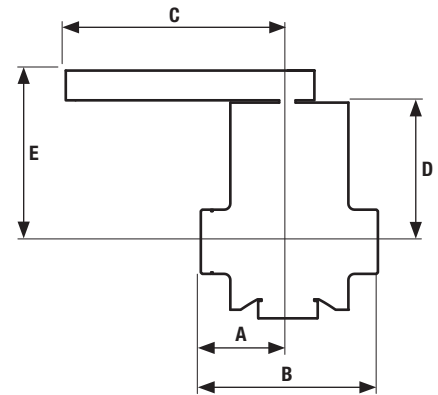

Cv				
Bore (inches)	Pipe Size (inches) / Schedule			
	1/2 Sch 160	1/2 Sch XXS	3/4 Sch 160	3/4 Sch XXS
0.38	40	19	18	36

Temperature vs Pressure — Limited Class Ratings

Class	Mat'l.	Temperature (°F)																		
		-20 to 100	200	300	400	500	600	650	700	750	800	850	900	950	1000	1050	1100			
ASME 600 Maximum Pressure (psig)	F22 ²	1500	1500	1480	1455	1450	1440	1430	1415	1415	1415	1355	1200	953	688	446	282			
	A105 ³	1500	1500	1480	1465	1465	1465	1430	1380	1270	1030	—	—	—	—	—	—			
	F91	1500	1500	1500	1500	1500	1500	1500	1465	1460	1440	1355	1200	953	862	862	775			
ASME 900 Maximum Pressure (psig)	F22 ²	2250	2250	2220	2185	2175	2165	2145	2120	2120	2120	2030	1800	1433	1045	681	426			
	A105 ³	2250	2250	2220	2200	2200	2200	2145	2075	1905	1545	—	—	—	—	—	—			
	F91	2250	2250	2250	2250	2250	2250	2250	2200	2185	2160	2030	1800	1433	1311	1311	1175			
ASME 1500 Maximum Pressure (psig)	F22 ²	3750	3750	3695	3640	3620	3605	3580	3535	3535	3535	3385	3000	2412	1785	1170	732			
	A105 ³	3750	3750	3700	3665	3665	3665	3575	3455	3170	2570	—	—	—	—	—	—			
	F91	3750	3750	3750	3750	3750	3750	3750	3665	3645	3600	3385	3000	2412	2250	2250	2015			
Class	Mat'l.	Temperature (°C)																		
		-29 to 38	50	100	150	200	250	300	325	350	375	400	425	450	475	500	538	550	575	600
ASME 600 Maximum Pressure (barg)	F22 ²	103	103	103	102	100	100	100	99	98	98	98	98	94	86	72	47	40	27	18
	A105 ³	103	103	103	102	101	101	101	100	98	94	87	72	—	—	—	—	—	—	
	F91	103	103	103	103	103	103	103	103	103	101	101	99	95	86	72	59	59	59	50
ASME 900 Maximum Pressure (barg)	F22 ²	155	155	155	153	151	150	149	149	148	146	146	146	141	128	109	72	61	41	27
	A105 ³	155	155	155	153	152	152	152	150	147	141	130	108	—	—	—	—	—	—	
	F91	155	155	155	155	155	155	155	155	154	152	151	149	143	128	109	90	90	89	76
ASME 1500 Maximum Pressure (barg)	F22 ²	259	259	258	255	251	250	249	248	246	244	244	244	236	214	183	123	104	70	46
	A105 ³	259	259	259	255	253	253	253	251	245	236	217	180	—	—	—	—	—	—	
	F91	259	259	259	259	259	259	259	259	257	253	251	248	241	214	183	155	155	153	130

²F22 not recommended for prolonged use above 1100°F / 593°C per ASME B16.34.

³A105 not recommended for prolonged use above 800°F / 427°C per ASME B16.34.

RSVP

ASME 600 / 900 / 1500 Limited Class



Applications

Boiler drains
 Feedwater drains
 Steam drum vents
 Isolation valve for bypass lines
 Economizer header drains

End Connections

Socketweld
 Buttweld
 Flanged¹

Sizes

3/4 to 2-1/2 inch

¹ Available Upon Request

Features

Ball and Seats

- Mate-lapped for 100% contact
- Ensures absolute shutoff
- Corrosion resistant
- Seats are protected from flow in open / closed position
- Inconel 718 CC upgrade available to provide additional resistance to corrosion¹

Mechanical Precision Stop

- Prevents turning ball 180°
- Eliminates misalignment

Stem & Packing Arrangement

- Live Loading
- Quarter-turn non-rising stem does not deteriorate packing
- Extensive stuffing box
- Dual anti-extrusion rings keep packing in place

Rigid Mounting Bracket

- Designed to support actuator in any position

Seat Spring

- Assisted by line pressure, provides a constant mechanical force on ball against seat to maintain seal

Bill of Materials

Item No.	Description	Material
1	Ball	410SS / CC Coated or Inconel 718 / CC Coated
2	Seat	410SS / CC Coated or Inconel 718 / CC Coated
3	Spring	Inconel 718
4	Body	A182 F22 A105 A182 F91
5	Stem	A276 GR431 Nitrided
6	Live Loading	Inconel 718
7	Gland Thruster	316 Nitrided
8	Gland Flange	410SS
9	Stem Packing	Expanded Graphite
10	Anti-Extrusion Rings	Braided Graphite w/ Inconel Wires
11	Metal Anti-Extrusion Ring	316SS
12	Retaining Ring	A638 660

- Standard four-year warranty; one-year warranty on high-cycle applications (1 cycle per day, 365 days per year)
- Patented design

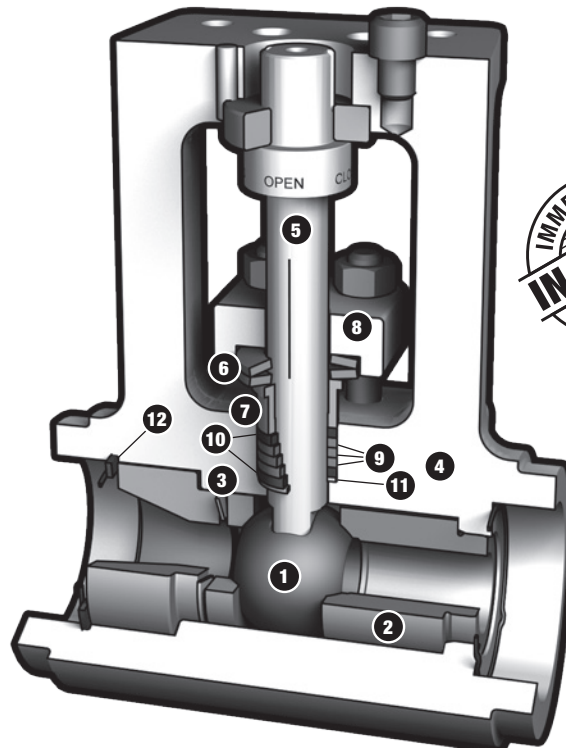

RSVP

Optimized for Power

Dimensions ² (in)								
Model	Bore	SW End	A	B	C	D	E	Weight
RSVP-UC	0.63	3/4	3.73	6.25	9.79	5.03	6.50	15 lb
		1, 1-1/2	2.50	5.00	9.79	5.03	6.50	15 lb
RSVP-UF	1.00	1-1/2, 2	3.19	6.38	21.56	6.63	8.80	32 lb
RSVP-UL	1.30	2	3.51	7.5	22.38	7.63	10.12	54 lb
		2-1/2	3.75	7.5	22.38	7.63	10.12	53 lb
RSVP-UM ³	1.50	2	5.59	9.59	—	7.63	—	61 lb
		2-1/2	3.88	7.75	—	7.63	—	58 lb

Dimensions ² (mm)								
Model	Bore	SW (DN)	A	B	C	D	E	Weight
RSVP-UC	16	20	95	159	249	128	165	7 Kg
		25, 40	63.5	127	249	128	165	7 Kg
RSVP-UF	25	40, 50	81	162	548	168	224	15 Kg
RSVP-UL	33	50	89	191	568	194	257	24 Kg
		65	95	191	568	194	257	24 Kg
RSVP-UM ³	38	50	142	244	—	194	—	28 Kg
		65	99	197	—	194	—	26 Kg

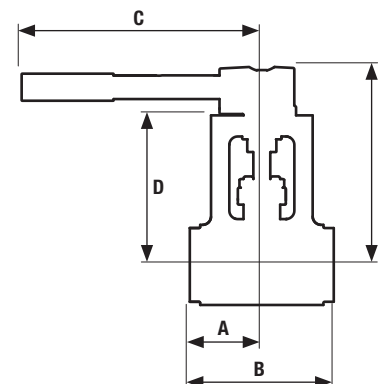

² Consult factory for F91 dimensions.

³ RSVP-UM is designed to meet ASME TDP-1 1998 full-bore and reliability requirements, and is a non-standard stock item.

Temperature vs Pressure — Limited Class Ratings

Class	Mat'l.	Temperature (°F)																		
		-20 to 100	200	300	400	500	600	650	700	750	800	850	900	950	1000	1050	1100			
ASME 600 Maximum Pressure (psig)	F22 ⁴	1500	1500	1480	1455	1450	1440	1430	1415	1415	1415	1355	1200	953	688	446	282			
	A105 ⁵	1500	1500	1480	1465	1465	1465	1430	1380	1270	1030	—	—	—	—	—	—			
	F91	1500	1500	1500	1500	1500	1500	1500	1465	1460	1440	1355	1200	953	862	862	775			
ASME 900 Maximum Pressure (psig)	F22 ⁴	2250	2250	2220	2185	2175	2165	2145	2120	2120	2120	2030	1800	1433	1045	681	426			
	A105 ⁵	2250	2250	2220	2200	2200	2200	2145	2075	1905	1545	—	—	—	—	—	—			
	F91	2250	2250	2250	2250	2250	2250	2250	2200	2185	2160	2030	1800	1433	1311	1311	1175			
ASME 1500 Maximum Pressure (psig)	F22 ⁴	3750	3750	3695	3640	3620	3605	3580	3535	3535	3535	3385	3000	2412	1785	1170	732			
	A105 ⁵	3750	3750	3700	3665	3665	3665	3575	3455	3170	2570	—	—	—	—	—	—			
	F91	3750	3750	3750	3750	3750	3750	3750	3665	3645	3600	3385	3000	2412	2250	2250	2015			
Class	Mat'l.	Temperature (°C)																		
		-29 to 38	50	100	150	200	250	300	325	350	375	400	425	450	475	500	538	550	575	600
ASME 600 Maximum Pressure (barg)	F22 ⁴	103	103	103	102	100	100	100	99	98	98	98	98	94	86	72	47	40	27	18
	A105 ⁵	103	103	103	102	101	101	101	100	98	94	87	72	—	—	—	—	—	—	
	F91	103	103	103	103	103	103	103	103	103	101	101	99	95	86	72	59	59	59	50
ASME 900 Maximum Pressure (barg)	F22 ⁴	155	155	155	153	151	150	149	149	148	146	146	146	141	128	109	72	61	41	27
	A105 ⁵	155	155	155	153	152	152	152	150	147	141	130	108	—	—	—	—	—	—	
	F91	155	155	155	155	155	155	155	155	154	152	151	149	143	128	109	90	90	89	76
ASME 1500 Maximum Pressure (barg)	F22 ⁴	259	259	258	255	251	250	249	248	246	244	244	244	236	214	183	123	104	70	46
	A105 ⁵	259	259	259	255	253	253	253	251	245	236	217	180	—	—	—	—	—	—	
	F91	259	259	259	259	259	259	259	259	257	253	251	248	241	214	183	155	155	153	130

⁴ F22 not recommended for prolonged use above 1100°F / 593°C per ASME B16.34.

⁵ A105 not recommended for prolonged use above 800°F / 427°C per ASME B16.34.

Cv

Bore (inches)	Pipe Size (inches) / Schedule									
	3/4 Sch 160	3/4 Sch XXS	1 Sch 160	1 Sch XXS	1-1/2 Sch 160	1-1/2 Sch XXS	2 Sch 160	2 Sch XXS	2-1/2 Sch 160	2-1/2 Sch XXS
0.63	40	19	18	38	11	13	—	—	—	—
1.00	—	—	—	—	43	70	33	37	—	—
1.30	—	—	—	—	—	—	90	117	66	82
1.50	—	—	—	—	—	—	144	242	103	145

RSVP

ASME 3100 Limited Class

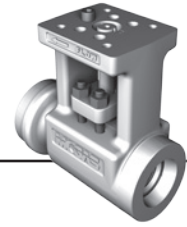

Applications

Boiler drains
Turbine drains
Above and below seat drains
Feedwater drains
Steam drum vents
Superheater vents and drains
Sootblower isolation
Isolation valve for bypass lines
Economizer header drains

End Connections

Socketweld
Buttweld
Flanged¹

Sizes

3/4 to 2-1/2 inch

¹ Available Upon Request

Features

Inconel 718 Ball and Seats

- Mate-lapped for 100% contact
- Ensures absolute shutoff
- Corrosion resistant
- Seats are protected from flow in open / closed position

Chromium Carbide Coating

Advantages

- Withstands thermal shock
- Handles high cycling applications
- High strain to fracture
- Maintains strength of base metal
- Erosion resistant

Rigid Mounting Bracket

- Designed to support actuator in any position

Stem & Packing Arrangement

- Live loading
- Quarter-turn non-rising stem does not deteriorate packing
- Extensive stuffing box
- Dual anti-extrusion rings keep packing in place

Mechanical Precision Stop

- Prevents turning ball 180°
- Eliminates misalignment

Seat Spring

- Assisted by line pressure, provides a constant mechanical force on ball against seat to maintain seal

Bill of Materials

Item No.	Description	Material
1	Ball	Inconel 718 / CC Coated
2	Seat	Inconel 718 / CC Coated
3	Spring	Inconel 718
4	Body	A182 F22 A105 A182 F91
5	Stem	431SS Nitrided
6	Stem Bushing	431SS / Melonite and Xylan Coated
7	Gland Thruster	431SS / Melonite and Xylan Coated
8	Gland Flange	431SS / Nitrided
9	Stem Packing	Expanded Graphite
10	Anti-Extrusion Rings	Braided Graphite w/ Inconel Wires
11	Metal Anti-Extrusion Ring	316SS
12	Pusher Seat	431SS / Nitrided

- Integral vented body design allows installation per ASME B31.1 PWHT requirements
- Standard four-year warranty; one-year warranty on high-cycle applications (1 cycle per day, 365 days per year)
- Patented design

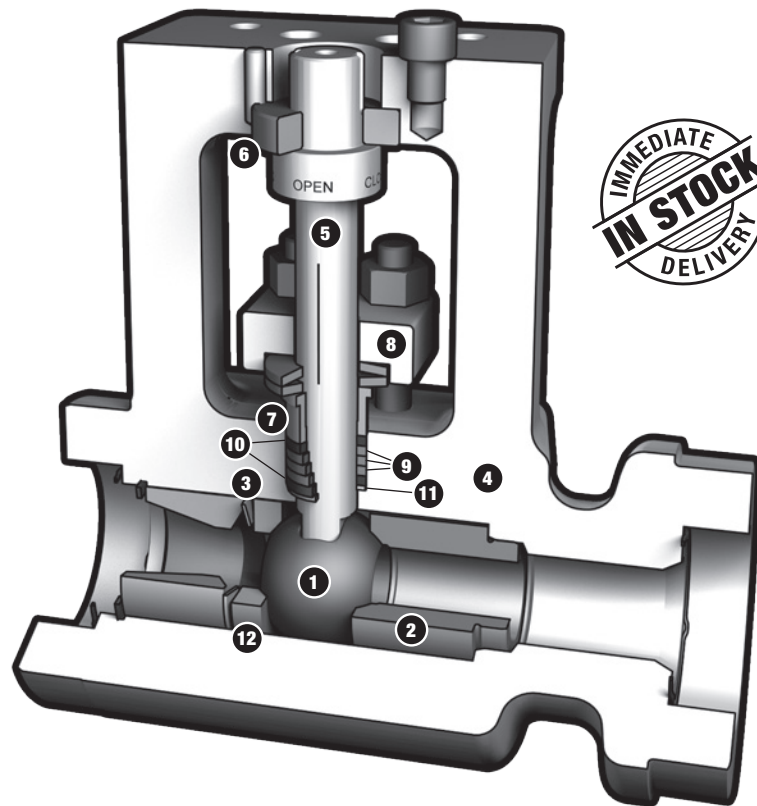

RSVP

Withstands Severe Temperature Shocks

Dimensions (in)

Model	Bore	SW End	A	B	C	D	E	Weight
RSVP-UC	0.63	3/4	4.09	8.34	11.75	6.00	7.78	24 lb
		1, 1-1/2	2.88	7.13	11.75	6.00	7.78	24 lb
RSVP-UF	1.00	1-1/2, 2	3.42	8.50	21.56	6.63	8.80	43 lb
RSVP-UL	1.30	2	3.75	9.06	22.38	7.63	10.12	66 lb
		2-1/2	3.75	9.06	22.32	7.63	10.12	66 lb

Dimensions (mm)

Model	Bore	SW (DN)	A	B	C	D	E	Weight
RSVP-UC	16	20	105	213	298	152	198	11 Kg
		25, 40	73	181	298	152	198	11 Kg
RSVP-UF	25	40, 50	87	216	548	168	224	20 Kg
RSVP-UL	33	50	94	230	568	194	257	30 Kg
		65	95	230	568	194	257	30 Kg

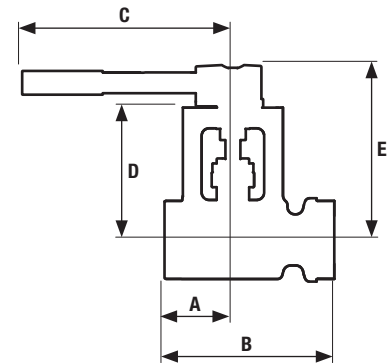

Cv

Bore (inches)	Pipe Size (inches) / Schedule							
	1 Sch 160	1 Sch XXS	1-1/2 Sch 160	1-1/2 Sch XXS	2 Sch 160	2 Sch XXS	2-1/2 Sch 160	2-1/2 Sch XXS
0.63	24	32	16	18	—	—	—	—
1.00	—	—	55	67	43	46	—	—
1.30	—	—	—	—	103	118	77	89

Temperature vs Pressure — Limited Class Ratings

Class	Mat'l.	Temperature (°F)																		
		-20 to 100	200	300	400	500	600	650	700	750	800	850	900	950	1000	1050	1100			
ASME 3100 Maximum Pressure (psig)	F22 ²	7750	7750	7639	7520	7484	7452	7396	7308	7308	7308	7000	6200	5098	3983	2604	1635			
	A105 ³	7750	7750	7750	7651	7572	7572	7572	7391	7142	6554	5314	—	—	—	—	—			
	F91	7750	7750	7750	7750	7750	7750	7750	7750	7576	7528	7440	7000	6200	5098	5013	5013	4495		
Class	Mat'l.	Temperature (°C)																		
		-29 to 38	50	100	150	200	250	300	325	350	375	400	425	450	475	500	538	550	575	600
ASME 3100 Maximum Pressure (barg)	F22 ²	534	534	533	527	519	517	514	513	508	504	504	504	488	442	386	275	233	157	103
	A105 ³	534	534	534	527	523	522	518	505	487	449	372	—	—	—	—	—	—	—	
	F91	534	534	534	534	534	534	534	534	531	522	519	513	510	442	386	346	346	341	290

² F22 not recommended for prolonged use above 1100°F / 593°C per ASME B16.34.

³ A105 not recommended for prolonged use above 800°F / 427°C per ASME B16.34.

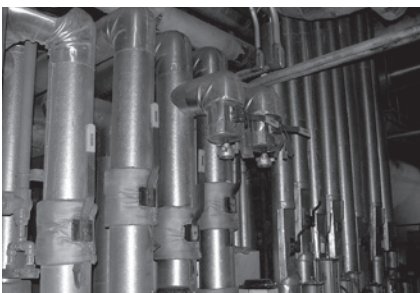

Wall of MOGAS RSVP valves for main steam drain have outperformed the original globe valves. Exposed to 950°F at 1875 psi (510°C at 129 bar) while online, it is critical that these valves operate and seal dependably.

RSVP

ASME 4500 Limited Class

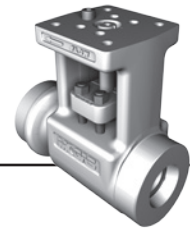

Applications

Boiler drains
Turbine drains
Above and below seat drains
Feedwater drains
Steam drum vents
Superheater vents and drains
Sootblower isolation
Isolation valve for bypass lines
Economizer header drains

End Connections

Socketweld
Buttweld
Flanged¹

Sizes

3/4 to 2-1/2 inch

¹ Available Upon Request

Features

Inconel 718 Ball and Seats

- Mate-lapped for 100% contact
- Ensures absolute shutoff
- Corrosion resistant
- Seats are protected from flow in open / closed position

Chromium Carbide Coating

Advantages

- Withstands thermal shock
- Handles high cycling applications
- High strain to fracture
- Maintains strength of base metal
- Erosion resistant

Rigid Mounting Bracket

- Designed to support actuator in any position

Stem & Packing Arrangement

- Live loading
- Quarter-turn non-rising stem does not deteriorate packing
- Extensive stuffing box
- Dual anti-extrusion rings keep packing in place

Mechanical Precision Stop

- Prevents turning ball 180°
- Eliminates misalignment

Seat Spring

- Assisted by line pressure, provides a constant mechanical force on ball against seat to maintain seal

Bill of Materials

Item No.	Description	Material
1	Ball	Inconel 718 / CC Coated
2	Seat	Inconel 718 / CC Coated
3	Spring	Inconel 718
4	Body	A182 F22 A182 F91
5	Stem	A276 GR 431 Nitrided
6	Stem Bushing	431SS / Melonite and Xylan Coated
7	Gland Thruster	431SS Melonite and Xylan Coated
8	Gland Flange	410SS
9	Stem Packing	Expanded Graphite
10	Anti-Extrusion Rings	Braided Graphite w/ Inconel Wires
11	Metal Anti-Extrusion Ring	316SS
12	Pusher Seat	431SS / Nitrided
13	Live Loading	Inconel 718

- Integral vented body design allows installation per ASME B31.1 PWHT requirements
- Standard four-year warranty; one-year warranty on high-cycle applications (1 cycle per day, 365 days per year)
- Patented design

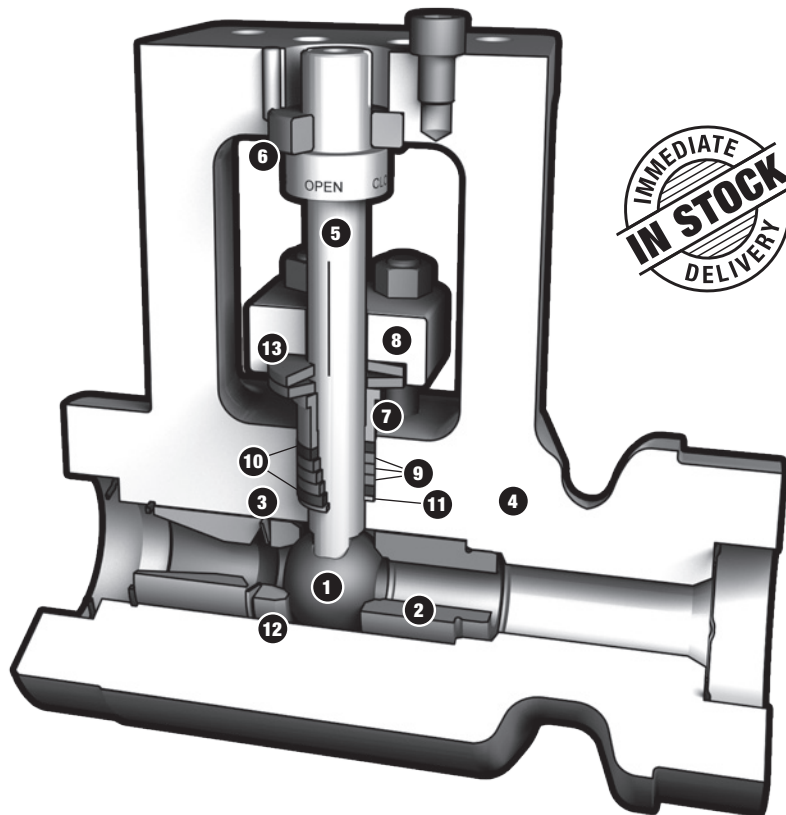

RSVP

Engineered for Extreme Conditions

Dimensions (in)

Model	Bore	SW End	A	B	C	D	E	Weight
RSVP-UC	0.63	3/4	4.72	9.47	11.75	6.00	7.78	47 lb
		1, 1-1/2	3.25	8.00	11.75	6.00	7.78	47 lb
RSVP-UF	1.00	1-1/2, 2	4.29	10.38	22.38	7.48	9.88	76 lb
		2-1/2	4.29	10.38	22.38	7.48	9.88	76 lb

Dimensions (mm)

Model	Bore	SW (DN)	A	B	C	D	E	Weight
RSVP-UC	16	20	120	241	298	152	198	21 Kg
		25, 40	83	203	298	152	198	21 Kg
RSVP-UF	25	40, 50	109	264	568	190	251	34 Kg
		65	109	264	568	190	251	34 Kg

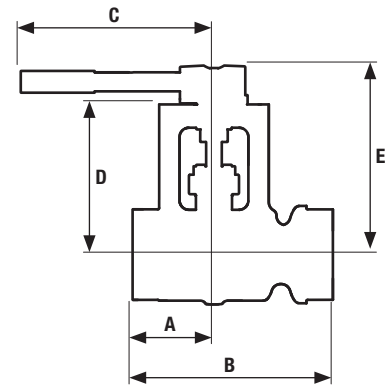

Cv

Bore (inches)	Pipe Size (inches) / Schedule							
	1 Sch 160	1 Sch XXS	1-1/2 Sch 160	1-1/2 Sch XXS	2 Sch 160	2 Sch XXS	2-1/2 Sch 160	2-1/2 Sch XXS
0.63	21	25	12	14	12	13	—	—
1.00	—	—	—	—	38	43	33	37

Temperature vs Pressure — Limited Class Ratings

Class	Mat'l.	Temperature (°F)																		
		-20 to 100	200	300	400	500	600	650	700	750	800	850	900	950	1000	1050	1100			
ASME 4500 Maximum Pressure (psig)	F22²	11250	11250	10090	10915	10865	10815	10735	10605	10605	10605	10160	9000	7556	6213	4064	2546			
	F91	11250	11250	11250	11250	11250	11250	11250	10995	10930	10800	10160	9000	7556	7556	7556	7006			
Class	Mat'l.	Temperature (°C)																		
		-29 to 38	50	100	150	200	250	300	325	350	375	400	425	450	475	500	538	550	575	600
ASME 4500 Maximum Pressure (barg)	F22²	775	775	774	764	753	750	747	744	738	731	731	731	708	641	572	428	363	245	160
	F91	775	775	775	775	775	775	775	775	775	771	757	753	744	756	641	572	539	539	531

²F22 not recommended for prolonged use above 1100°F / 593°C per ASME B16.34.

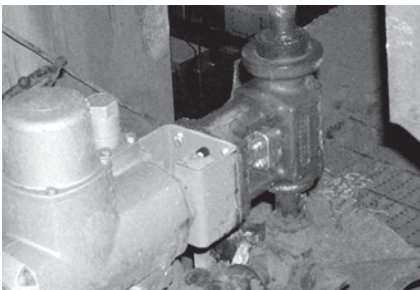

This ASME 4500 Class RSVP convection vent valve was designed to handle extremely high pressure and elevated temperatures coming from the boiler.

Gen-X

ASME 600 / 900 / 1500 Limited Class

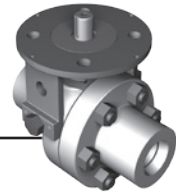

Applications

Cold Reheat Drains
850°F / 454°C or Below

End Connections

Socketweld

Size

2 inch

Features

ASME TDP-1 1998

- Built for the prevention of water induction into steam turbines in Cold Reheat applications
- Meets and exceeds full, 2-inch bore reliability requirements

Two-Piece, Cast Body

- Available in materials WCC, WC9 and C12A
- Allows for valve repairability

Seat Spring

- Assisted by line pressure, provides a constant mechanical force on ball against seat to maintain seal

Ball & Seats

- Mate-lapped for 100% sealing contact
- Ensures absolute shutoff
- Corrosion resistant
- Seats are protected from flow in open / closed position
- Seats are field replaceable

Inner Stem Seals

- Provides a reliable combination of bearing and pressurized stem seal

Quarter-turn, Non-rising Stem

- Live loading
- Quick open / close operation
- Extends the packing life

Bill of Materials

Item No.	Description	Material
1	Ball	410SS / CC Coated
2	Seat	410SS / CC Coated
3	Spring	Inconel 718
4	Body	WCC, WC9, C12A
5	End Connection	WCC, WC9, C12A
6	Gasket	Spiral Wound
7	Stem	A638 GR660
8	Stem Seal Bearing	410SS / CC Coated Stellite #3
9	Gland Flange	316SS / Moly Coated
10	Stem Packing	Expanded Graphite
11	Anti-Extrusion Ring	Braided Graphite w/ Inconel Wires
12	Pusher Seat	410SS / CC Coated

- Available for Quick Delivery

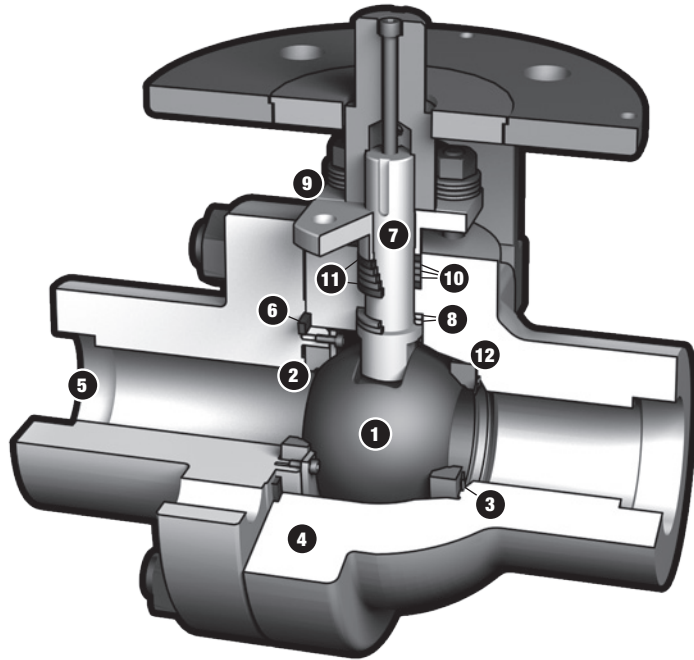

Gen-X

Full Bore Valve Designed to Meet ASME TDP-1 1998

Dimensions (in)

Valve Size	Bore	Class	A	B	C	D	Weight
2	2.00	150 – 600	5.19	11.50	6.23	7.74	82 lb
2	1.87	900 – 1500	5.10	11.50	6.23	7.74	80 lb

Dimensions (mm)

DN	Bore	Class	A	B	C	D	Weight
50	50	150 – 600	132	292	158	197	37 Kg
50	48	900 – 1500	130	292	158	197	36 Kg

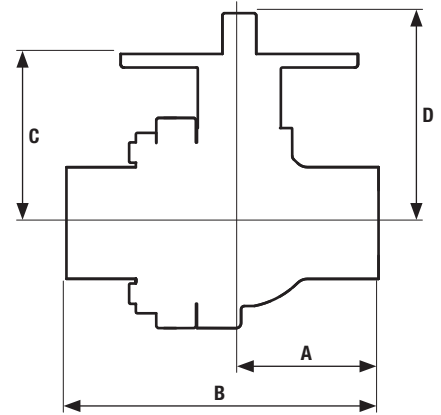

Cv

Bore (inches)	Class	Pipe Size (inches) / Schedule							
		2 Sch 40	2 Sch 80	2 Sch 160	3 Sch 40	3 Sch 80	3 Sch 160	4 Sch 40	
2.00	150 – 600	371	377	332	167	163	—	137	
1.87	900 – 1500	264	317	282	—	145	163	—	

Temperature vs Pressure — Limited Class Ratings

Class	Mat'l.	Temperature (°F)																		
		-20 to 100	200	300	400	500	600	650	700	750	800	850	900	950	1000	1050	1100			
ASME 600 Maximum Pressure (psig)	WCC	1500	1500	1500	1500	1500	1500	1500	1425	1270	1030	N/A ¹	N/A ¹	N/A ¹	N/A ¹	N/A ¹	N/A ¹			
	WC9	1500	1500	1480	1455	1450	1440	1430	1415	1415	1415	1355	1200	953	688	446	282			
	C12A	1500	1500	1500	1500	1500	1500	1500	1465	1460	1440	1355	1200	953	862	862	775			
ASME 900 Maximum Pressure (psig)	WCC	2250	2250	2250	2250	2250	2250	2250	2140	1905	1545	N/A ¹	N/A ¹	N/A ¹	N/A ¹	N/A ¹	N/A ¹			
	WC9	2250	2250	2250	2185	2175	2165	2145	2120	2120	2120	2030	1800	1433	1045	681	426			
	C12A	2250	2250	2250	2250	2250	2250	2250	2200	2185	2160	2030	1800	1433	1311	1311	1175			
ASME 1500 Maximum Pressure (psig)	WCC	3750	3750	3750	3750	3750	3750	3750	3565	3170	2570	N/A ¹	N/A ¹	N/A ¹	N/A ¹	N/A ¹	N/A ¹			
	WC9	3750	3750	3695	3640	3620	3605	3580	3535	3535	3535	3385	3000	2412	1785	1170	732			
	C12A	3750	3750	3750	3750	3750	3750	3750	3665	3645	3600	3385	3000	2412	2250	2250	2015			
Class	Mat'l.	Temperature (°C)																		
		-29 to 38	50	100	150	200	250	300	325	350	375	400	425	450	475	500	538	550	575	600
ASME 600 Maximum Pressure (barg)	WCC	103	103	103	103	103	103	103	103	102	97	87	72	N/A ¹	N/A ¹	N/A ¹	N/A ¹	N/A ¹	N/A ¹	N/A ¹
	WC9	103	103	103	102	100	100	100	99	98	98	98	98	94	86	72	47	40	27	18
	C12A	103	103	103	103	103	103	103	103	103	101	101	99	95	86	72	59	59	59	50
ASME 900 Maximum Pressure (barg)	WCC	155	155	155	155	155	155	155	155	153	145	130	108	N/A ¹	N/A ¹	N/A ¹	N/A ¹	N/A ¹	N/A ¹	N/A ¹
	WC9	155	155	155	153	151	150	149	149	148	146	146	146	141	128	109	72	61	41	27
	C12A	155	155	155	155	155	155	155	155	154	152	151	149	143	128	109	90	90	89	76
ASME 1500 Maximum Pressure (barg)	WCC	259	259	259	259	259	259	259	259	256	242	217	180	N/A ¹	N/A ¹	N/A ¹	N/A ¹	N/A ¹	N/A ¹	N/A ¹
	WC9	259	259	258	255	251	250	249	248	246	244	244	244	236	214	183	123	104	70	46
	C12A	259	259	259	259	259	259	259	259	257	253	251	248	241	214	183	155	155	153	130

¹ WCC not recommended for prolonged use above 800°F / 427°C per ASME B16.34.

SC-3 Piece

ASME 2500 Class

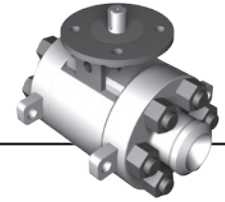

Applications

Sootblower header
 Hot reheat spray
 Superheater spray
 Main turbine drain valve
 Boiler feed pump
 Main steam supply
 Main boiler drain
 Booster pump isolation

End Connections

Buttweld
 Socketweld¹
 Flanged¹
 Clamped¹

Sizes

2 to 6 inch
 Stocked with 2 inch bore

¹ Available Upon Request

Features

In-line Repairability

- Three-piece valve assembly
- Valve body can be easily removed while end connections remain in-line
- Allows valve body to be tested after repair, prior to insertion back in-line

Ball & Seats

- Mate-lapped for 100% sealing contact
- Ensures absolute shutoff
- Corrosion resistant
- Seats are protected from flow in open / closed position
- Seats are field replaceable

Seat Spring

- Assisted by line pressure, provides a constant mechanical force on ball against seat to maintain seal

Body Gaskets

- Two proprietary body joint seals of Inconel 718
- Gold plating of gaskets creates a metallic permatext to assist in sealing
- Lowers contact stresses
- Ensures zero body leaks

Quarter-turn, Non-rising Stem

- Live loading
- Quick open / close operation
- Extends the packing life

Bill of Materials

Item No.	Description	Material
1	Ball	410SS / CC Coated
2	Seat	410SS / CC Coated
3	Spring	Inconel 718
4	Body	A182 F22
5	Gasket	Inconel 718 Gold Plated
6	Stem	A638 GR660
7	Inner Stem Seal	410 / CC Coated
8	Live Loading	Inconel 718
9	Gland Thruster	316SS
10	Gland Flange	410SS
11	Stem Packing	Expanded Graphite
12	Anti-Extrusion Rings	Braided Graphite w/ Inconel Wires
13	Nut	A194 GR4
14	Access Plug	A182 F22

- Available for Quick Delivery

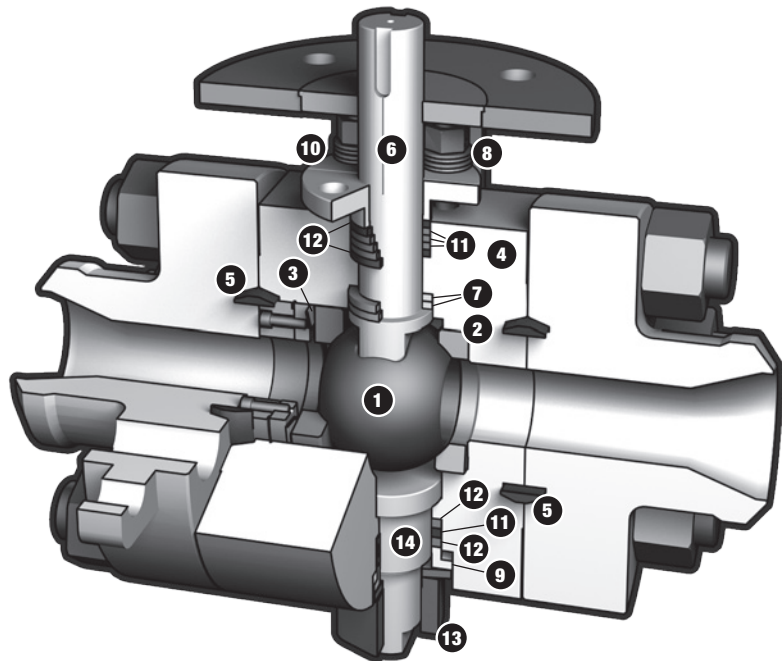

SC-3 Piece

Flexibility of In-line Repair

Dimensions (in)						
Valve Size	Bore	A	B	C	D	Weight
2	2	10.00	20.00	2.38	7.31	259 lb
2-1/2	2	10.00	20.00	2.88	7.31	259 lb
3	2	11.38	22.75	3.50	7.31	265 lb
4	2	13.25	26.50	4.50	7.31	273 lb
6	2	18.00	36.00	6.63	7.31	310 lb

Dimensions (mm)						
DN	Bore	A	B	C	D	Weight
60	51	254	508	60	186	117 Kg
65	51	254	508	73	186	117 Kg
80	51	289	578	89	186	120 Kg
100	51	337	673	114	186	123 Kg
150	51	457	914	168	186	140 Kg

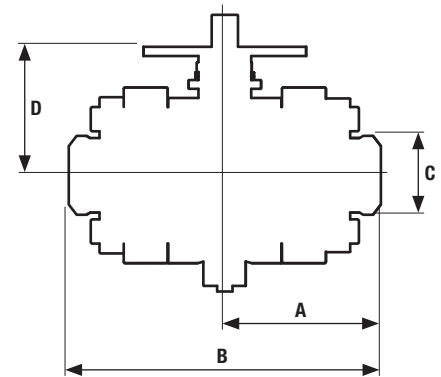

Cv										
Bore (inches)	Pipe Size (inches) / Schedule									
	2 Sch 160	2 Sch XXS	2-1/2 Sch 160	2-1/2 Sch XXS	3 Sch 160	3 Sch XXS	4 Sch 160	4 Sch XXS	6 Sch 160	6 Sch XXS
2.00	186	148	295	228	210	285	152	164	124	126

Temperature vs Pressure — Standard Class Ratings																				
Class	Mat'l.	Temperature (°F)																		
		-20 to 100	200	300	400	500	600	650	700	750	800	850	900	950	1000	1050	1100			
ASME 2500	F22 ²	6250	6250	6070	5880	5540	5040	4905	4730	4430	4230	4060	3745	3220	2230	1455	915			
Maximum Pressure (psig)																				
Class	Mat'l.	Temperature (°C)																		
		-29 to 38	50	100	150	200	250	300	325	350	375	400	425	450	475	500	538	550	575	600
ASME 2500	F22 ²	431	431	429	418	405	386	357	344	335	323	305	292	282	264	235	154	130	88	57
Maximum Pressure (barg)																				

²F22 not recommended for prolonged use above 1100°F / 593°C per ASME B16.34.

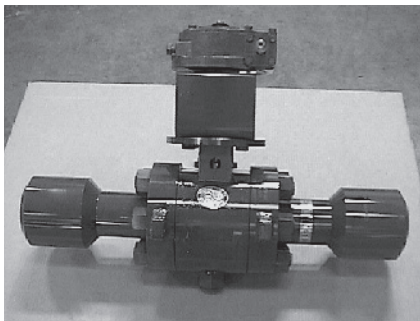

MOGAS was able to meet the customer's special requirements for unique fabricated end connections and specific top works.

Isolator

ASME 150 / 300 Class

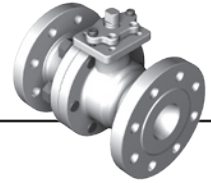

Applications

Fly Ash Slurries
 Fuel Oil Burner Supply
 Hot Well Pump Isolation
 Vent, Drain and Bypass

End Connections

Flanged
 Buttweld¹

Sizes

2 to 8 inch

¹ Available Upon Request

Features

Designed to meet Industrial Needs for Reliability and Economy

- Excellent value option for elevated temperatures with lower pressures
- Exceeds the design standards of ASME B16.34 and ASME B16.10
- Tested per MSS SP-61
- One year warranty

Full Bore

- Greatly minimizes any pressure drop
- Allows for higher Cv

Cast Body in CF8M (316 SS)

- Provides tight shutoff for temperatures up to 1100°F / 593°C
- Maximum cold working pressure of 720 psig / 50 bar(g)

Ball & Seats

- Mate-lapped for 100% sealing contact
- Ensures absolute shutoff
- Corrosion resistant
- Seats are protected from flow in open / closed position
- Seats are field replaceable

Quarter-turn, Non-rising Stem

- Live loading
- Quick open / close operation
- Extends the packing life

Seat Spring

- Assisted by line pressure, provides a constant mechanical force on ball against seat to maintain seal

Bill of Materials

Item No.	Description	Material
1	Ball	410SS or 316SS / CC Coated
2	Seat	410SS or 316SS / CC Coated
3	Seat	Stellite #3
4	Body	A351 CF8M (316SS)
5	Gasket	316SS Grafoil Filled
6	Spring	Inconel 718
7	Stem	A638 GR660
8	Gland Flange	304SS
9	Packing	Grafoil
10	Anti-Extrusion Rings	Grafoil / Carbon Fiber
11	Inner Stem Seal	410SS Nitrided

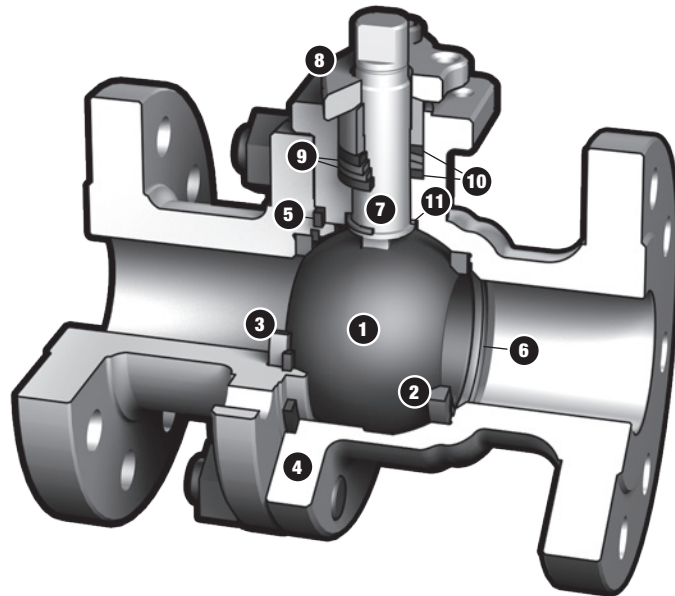

Isolator

Low Pressure Isolation Service

Dimensions (in)

Valve Size	Bore	Class	A	B	C	D	Weight
2	2.00	150	2.80	7.00	3.50	4.91	49 lb
	2.00	300	3.94	8.50	3.50	4.91	60 lb
3	3.00	150	3.70	8.00	4.53	6.62	53 lb
	3.00	300	4.85	11.13	4.53	6.62	77 lb
4	4.00	150	4.21	9.00	5.30	7.32	77 lb
	4.00	300	5.47	12.00	5.30	7.32	110 lb
6	6.00	150	6.77	15.50	7.49	10.73	180 lb
	6.00	300	7.14	15.88	7.49	10.73	238 lb
8	8.00	150	7.99	18.00	9.61	12.87	339 lb
	8.00	300	9.06	19.75	7.49	12.87	406 lb

Dimensions (mm)

DN	Bore	Class	A	B	C	D	Weight
50	50	150	71	178	88.9	125	22 Kg
	50	300	100	216	88.9	125	27 Kg
80	80	150	94	203	115	168	24 Kg
	80	300	123	283	115	168	35 Kg
100	100	150	107	229	135	186	35 Kg
	100	300	139	305	135	186	50 Kg
150	150	150	172	394	190	273	82 Kg
	150	300	181	403	190	273	108 Kg
200	200	150	203	457	244	327	154 Kg
	200	300	230	502	244	327	184 Kg

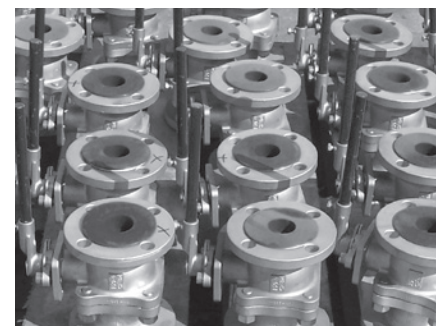
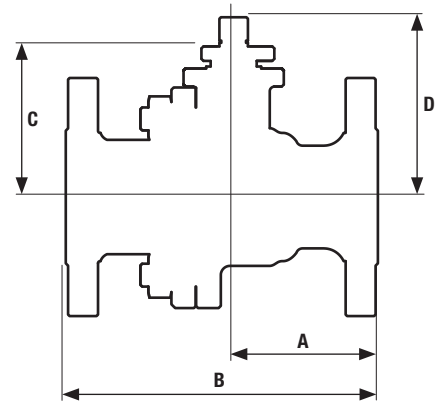

Isolators are a standard stock item. MOGAS keeps many assembled and available for immediate delivery, making the Isolator a great value for quick turnaround jobs.

Cv

Bore (inches)	Valve Size (inches)				
	2	3	4	6	8
2.00	498	—	—	—	—
3.00	—	1175	—	—	—
4.00	—	—	2159	—	—
6.00	—	—	—	5076	—
8.00	—	—	—	—	9300

Temperature vs Pressure — Standard Class Ratings

Class	Mat'l.	Temperature (°F)																		
		-20 to 100	200	300	400	500	600	650	700	750	800	850	900	950	1000	1050	1100			
ASME 150 Maximum Pressure (psig)	CF8M	275	235	215	195	170	140	125	110	95	80	65	50	35	20	20	20			
ASME 300 Maximum Pressure (psig)	CF8M	720	620	560	515	480	450	440	435	425	420	420	415	385	365	350	305			
Class	Mat'l.	Temperature (°C)																		
		-29 to 38	50	100	150	200	250	300	325	350	375	400	425	450	475	500	538	550	575	600
ASME 150 Maximum Pressure (barg)	CF8M	19	18	16	15	14	12	10	9	8	7	7	6	5	4	3	1	1 ²	1 ²	1 ²
ASME 300 Maximum Pressure (barg)	CF8M	50	48	42	39	36	33	32	31	30	30	29	29	29	29	28	25	25	24	20

² Flanged end valve ratings terminate at 1000°F / 538°C.

C-Series

ASME 150 – 4500 Class

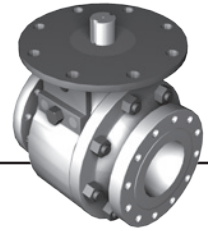

Applications

Control valve isolation
Main steam isolation
Feedwater heater isolation
Boiler feed pump isolation
Economizer isolation
Bottom Ash Isolation
Isolation Applications

End Connections

Per customer specification

Sizes

1/2 to 30 inch
Larger sizes available upon request

Features

Straight-through Bore Path

- Sealing surfaces not exposed to torturous effects of high pressure steam
- Greatly minimizes any pressure drops
- Allows for higher Cv
- Available in large bore sizes

Bidirectional Sealing

- Floating ball design

Ball & Seats

- Mate-lapped for 100% sealing contact
- Ensures absolute shutoff
- Corrosion resistant
- Seats are protected from flow in open / closed position
- Seats are field replaceable

Forged Body

- Designed to withstand high temperatures up to 1652°F / 900°C
- High pressures up to 30,000 psig

Inner Stem Seals

- Provides a reliable combination of bearing and pressurized stem seal

Seat Spring

- Assisted by line pressure, provides a constant mechanical force on ball against seat to maintain seal

Valve Sized Specifically for Customer Application Requirements

Bill of Materials

Item No.	Description	Material
1	Ball	410SS / CC Coated
2	Seat	410SS / CC Coated
3	Seat Spring	Inconel 718
4	Body	A182 F22 A105 A182 F91
5	Body Gasket	Inconel 600 Grafoil Filled or Inconel 718 / Gold Plated
6	Stem	17-4PH SS or A638 GR660
7	Stem Bushing	Coated Cast Iron
8	Inner Stem Seal	410SS / CC Coated
9	Gland Flange	316SS / Moly Coated
10	Stem Packing	Expanded Graphite
11	Anti-Extrusion Rings	Braided Graphite w/ Inconel Wires

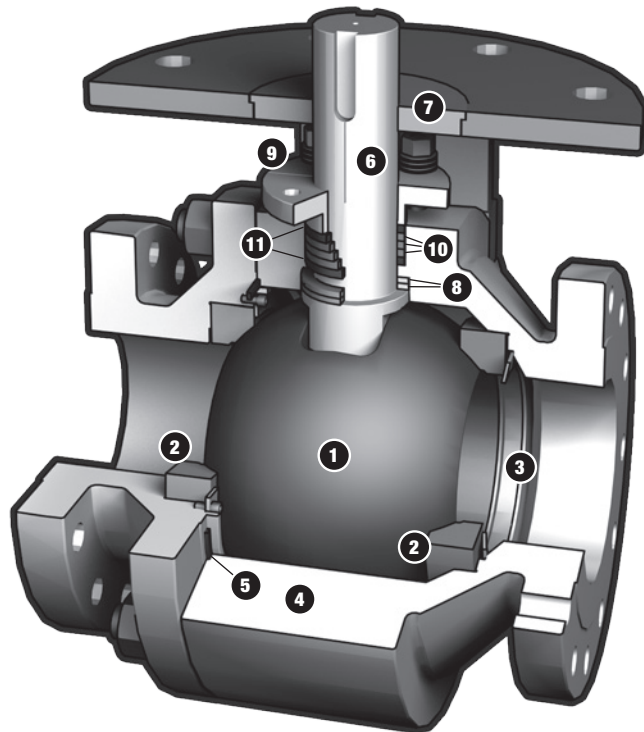

C-Series

Dependable Isolation Under Extreme Conditions

Bore Sizes ¹ (inches)							
NPS	Class						
	150	300	600	900	1500	2500	4500 ²
1/2	0.63 ³	0.63 ³	0.63 ³	0.63 ³	0.63 ³	0.63 ³	0.63
3/4	0.63 ⁴	0.63 ⁴	0.63 ⁴	0.63 ⁴	0.63 ⁴	0.63 ³	0.63
1	1.00	1.00	1.00	0.63 ⁴	0.63 ⁴	0.63 ⁴	0.63
1-1/2	1.30 ⁴	1.30 ⁴	1.30 ⁴	1.30 ⁴	1.30 ⁴	1.00 ⁴	1.00
2	2.00	2.00	2.00	1.87	1.87	1.30 ⁴	1.30
3	3.00	3.00	3.00	2.87	2.75	2.25	Note 2
4	4.00	4.00	4.00	3.87	3.62	2.87	Note 2
6	6.00	6.00	6.00	5.75	5.37	4.37	Note 2
8	8.00	8.00	7.87	7.50	7.00	5.75	Note 2
10	10.00	10.00	9.75	9.37	8.75	7.25	Note 2
12	12.00	12.00	11.75	11.12	10.37	8.62	Note 2
14	13.25	13.25	12.87	12.25	11.37	9.50	Note 2
16	15.25	15.25	14.75	14.00	13.00	10.87	Note 2

Bore Sizes ¹ (mm)							
DN	Class						
	150	300	600	900	1500	2500	4500 ²
15	16.0 ³	16.0 ³	16.0 ³	16.0 ³	16.0 ³	16.0 ³	16.0
20	16.0 ⁴	16.0 ⁴	16.0 ⁴	16.0 ⁴	16.0 ⁴	16.0 ³	16.0
25	25.4	25.4	25.4	16.0 ⁴	16.0 ⁴	16.0 ⁴	16.0
40	33.0 ⁴	33.0 ⁴	33.0 ⁴	33.0 ⁴	33.0 ⁴	28.4 ⁴	28.4
50	50.8	50.8	50.8	47.5	47.5	33.0 ⁴	33.0
80	76.2	76.2	76.2	72.9	69.9	57.2	Note 2
100	101.6	101.6	101.6	98.3	91.9	72.9	Note 2
150	152.4	152.4	152.4	146.1	136.4	111.0	Note 2
200	203.2	203.2	199.9	190.5	177.8	146.1	Note 2
250	254.0	254.0	247.7	238.0	222.3	184.2	Note 2
300	304.8	304.8	298.5	282.4	263.4	218.9	Note 2
350	336.6	336.6	326.9	311.2	288.8	241.3	Note 2
400	387.4	387.4	374.7	355.6	330.2	276.1	Note 2

Cv – Full Bore ¹							
Valve Size (inches)	Class						
	150	300	600	900	1500	2500	4500 ⁵
1/2	26	26	26	26	26	20	6
3/4	62	62	62	52	52	33	19
1	114	114	114	85	85	62	38
1-1/2	271	271	271	223	223	145	140
2	498	498	498	432	432	271	271
3	1176	1176	1176	1071	978	640	Note 2
4	2159	2159	2159	2014	1749	1071	Note 2
6	5076	5076	5076	4641	4019	2603	Note 2
8	9300	9300	8985	8120	7023	4641	Note 2
10	14866	14866	14096	12966	11289	7561	Note 2
12	21800	21800	20857	18579	16045	10881	Note 2
14	28838	28838	25249	22764	19466	13347	Note 2
16	36041	36041	33608	30124	25787	17712	Note 2

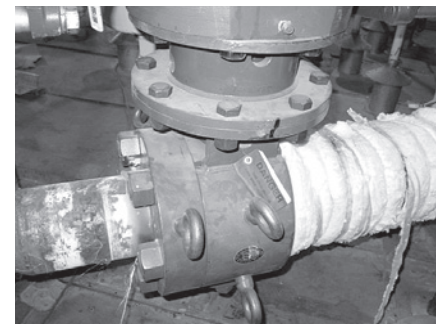
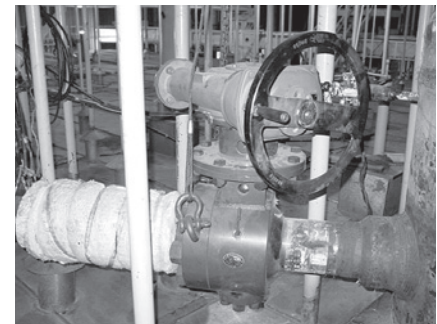

The C-Series valve was chosen for our customer's Boiler Purge System because of the rapid operation available with quick, quarter-turn rotation and absolute shutoff. These photos were taken during a routine maintenance shutdown with part of the insulation removed.

For reduced bore Cv calculations, contact the MOGAS Technology Development department.

¹ For larger sizes or values not specified, contact the MOGAS Engineering department.

² Due to various bore sizes, these values will be determined based on customer application.

³ Bore is larger than ASME B16.34 Appendix A.

⁴ Bore is smaller than ASME B16.34 Appendix A.

⁵ Cv information for the ASME 4500 Class is based upon the inside diameter of the pipe schedule, while the remaining values are based upon ASME 16.34.

PORV

ASME 1500 / 2500 / 4500 Class

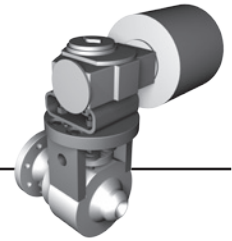

Applications

Overpressure relief of boiler/
superheater header

End Connections

Per customer specification

Sizes

2-1/2 to 4 inch

Standard Components

MOGAS ball valve
Actuator
Four-way electrically operated
solenoid valve
Control box
Limit switch

Optional Components

Pressure switch
Siphon tube
Air reservoir kit

Features

- ASME “V” stamp available
- Live loading ensures zero emissions from stem packing in the most severe temperature shocks
- High nickel alloy base ball and seat with a proprietary coating ensures superior wear resistance
- Quick operating pneumatic actuator decreases wear on sealing surfaces
- Field repairable

Bill of Materials

Item No.	Description	Material
1	Ball	Inconel 718 / Proprietary Coating
2	Seat	Inconel 718 / Proprietary Coating
3	Spring	Inconel 718
4	Body	A182 F22 A182 F91
5	Body Gasket	Inconel 718 Gold Plated
6	Stem	A638 GR660
7	Stem Bushing	431SS / Melonite and Xylan Coated
8	Live Loading	Inconel 718
9	Thrust Bearing	431SS / Melonite and Xylan Coated
10	Gland Flange	431SS / Moly Coated
11	Stem Packing	Expanded Graphite
12	Anti-Extrusion	Braided Graphite w/ Inconel Wires
13	Pusher Seat	431SS / Nitrided
14	Actuator	Pneumatic
	Solenoid Valve	Versa
	Limit Switch	Westlock
	Control Box	Model 307

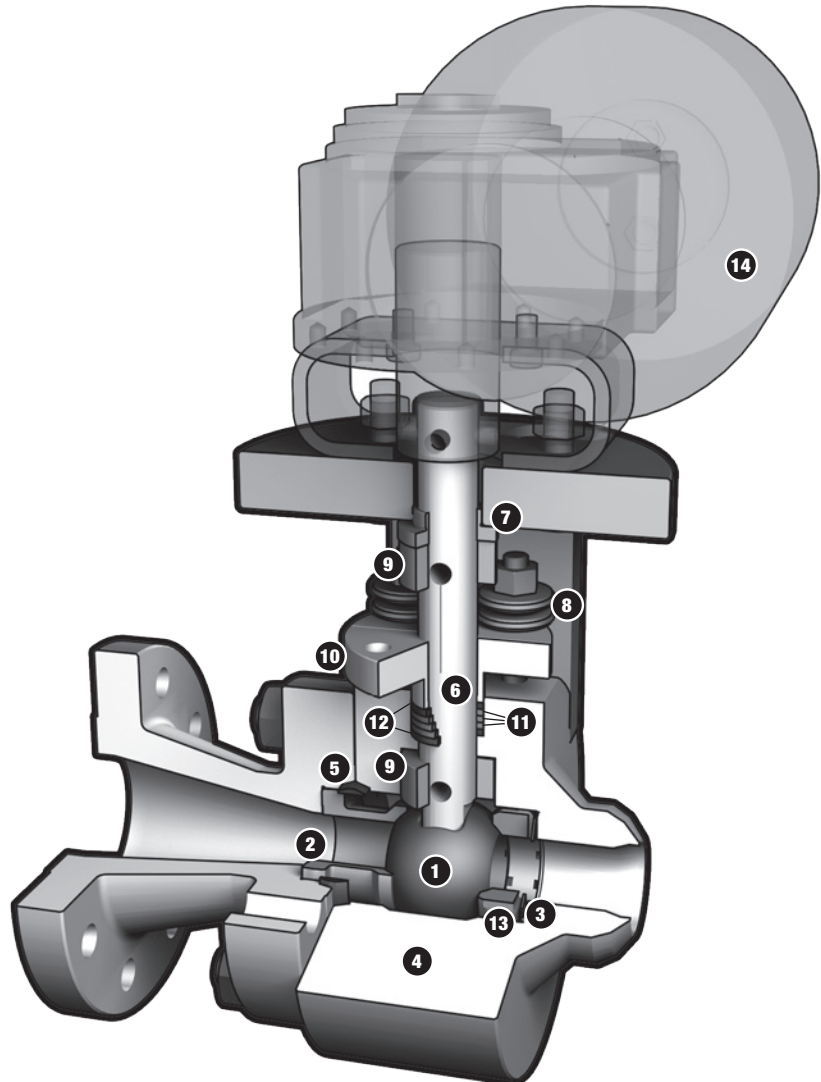

PORV

Prevents Excessive Pressure Build-up

High Performance Valve Contributes to Plant Safety

The MOGAS PORV, a pneumatic actuated pressure relieving valve, prevents excessive system pressure accumulation. The set pressure of the PORV is lower than that of the spring loaded safety valve to prevent or reduce the number of lifts of the safety valve, thus extending their life. The PORV is available either non-stamped or with the “V” stamp. The “V” stamped PORV has been flow certified by the National Board of Boiler and Pressure Vessel Inspectors.

The PORV operates as a system. The MOGAS ball valve is normally closed. The pressure switch senses steam pressure and closes an electrical switch when the pressure exceeds a predetermined point. This in turn energizes the solenoid valve, which pressurizes the “to open” cylinder port of the pneumatic actuator, opening the ball valve. When the pressure switch senses that the steam pressure has returned to normal, the electrical switch within the pressure switch opens, de-energizing the solenoid valve and closes the MOGAS ball valve.

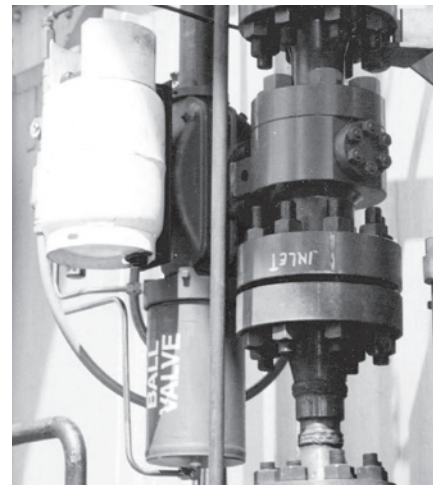

Dimensions (in)						
Model	Bore ¹	Standard Class	A	B	C	Weight w/o Actuator
PORV-UD	1.60	1500 / 2500	4.35	12.88	7.00	115 lb
	1.60	4500	6.00	17.00	10.58	115 lb
PORV-UK	1.81	1500 / 2500	7.00	15.38	10.67	250 lb
	1.81	4500	6.00	20.00	11.06	250 lb
PORV-UM	2.00	1500 / 2500	5.38	14.55	10.75	200 lb
	2.00	4500	6.50	19.97	11.83	200 lb

Dimensions (mm)						
Model	Bore ¹	Standard Class	A	B	C	Weight w/o Actuator
PORV-UD	43	1500 / 2500	110	327	178	52 Kg
	43	4500	152	432	269	52 Kg
PORV-UK	46	1500 / 2500	178	391	271	113 Kg
	46	4500	152	508	281	113 Kg
PORV-UM	50	1500 / 2500	137	370	254	90 Kg
	50	4500	165	507	295	90 Kg

¹For valve bore sizes 1.30 and 2.125 inches, contact factory for dimensions.

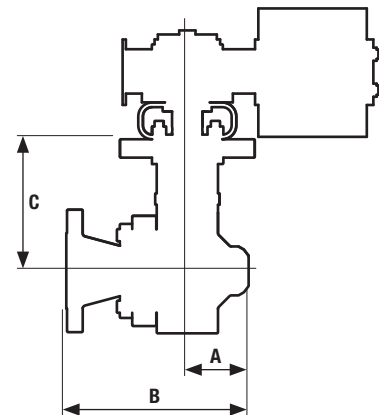

²F22 not recommended for prolonged use above 1100°F / 593°C per ASME B16.34.

Temperature vs Pressure — Standard Class Ratings

Class	Mat'l.	Temperature (°F)																		
		-20 to 100	200	300	400	500	600	650	700	750	800	850	900	950	1000	1050	1100			
ASME 1500 Maximum Pressure (psig)	F22 ²	3750	3750	3640	3530	3325	3025	2940	2840	2660	2540	2435	2245	1930	1335	875	550			
	F91	3750	3750	3640	3530	3325	3025	2940	2840	2660	2540	2435	2245	1930	1820	1800	1510			
ASME 2500 Maximum Pressure (psig)	F22 ²	6250	6250	6070	5880	5540	5040	4905	4730	4430	4230	4060	3745	3220	2230	1455	915			
	F91	6250	6250	6070	5880	5540	5040	4905	4730	4430	4230	4060	3745	3220	3030	3000	2515			
ASME 4500 Maximum Pressure (psig)	F22 ²	11250	11250	10925	10585	9965	9070	8825	8515	7970	7610	7305	6740	5795	4010	2625	1645			
	F91	11250	11250	10925	10585	9965	9070	8825	8515	7970	7610	7305	6740	5795	5450	5400	4525			
Class	Mat'l.	Temperature (°C)																		
		-29 to 38	50	100	150	200	250	300	325	350	375	400	425	450	475	500	538	550	575	600
ASME 1500 Maximum Pressure (barg)	F22 ²	259	259	258	251	243	232	214	207	201	194	183	175	169	158	141	92	78	53	34
	F91	259	259	258	251	243	232	214	207	201	194	183	175	169	158	141	125	124	120	98
ASME 2500 Maximum Pressure (barg)	F22 ²	431	431	429	418	405	386	357	344	335	323	305	292	282	264	235	154	130	88	57
	F91	431	431	429	418	405	386	357	344	335	323	305	292	282	264	235	209	208	200	163
ASME 4500 Maximum Pressure (barg)	F22 ²	776	776	773	753	730	695	643	620	603	582	549	525	507	475	423	277	235	158	103
	F91	776	776	773	753	730	695	643	620	603	582	549	525	507	475	423	376	374	359	293

SD

ASME 4500 Special Class

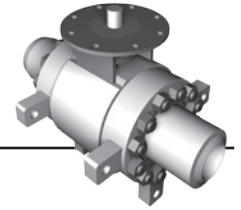

Applications

Steam Drain
Main Isolation

End Connections

Custom Bore

Sizes

Per Specification

Features

Replaceable Diffusion Plate

- Breaks down energy when valve is first opened
- Minimizes erosion

Reduced Bore

- Reliably handles dumping pressure during shutdowns / startups up to 4,000 psig
- Minimizes any possible damages of wiredraw during initial turbulent flow
- Handles high pressures at elevated temperatures

Seat Spring

- Assisted by line pressure, provides a constant mechanical force on ball against seat to maintain seal

Body Gaskets

- Two proprietary body joint seals of Inconel 718
- Gold plating of gaskets creates a metallic permatext to assist in sealing
- Lowers contact stresses
- Ensure zero body leaks

Ball & Seats

- Coating withstands severe thermal shocks and extreme pressure
- Protected from flow by the ball, thus reducing wear on sealing surfaces

Quarter-turn, Non-rising Stem

- Live loading
- Quick open / close operation
- Extends the packing life

Bill of Materials

Item No.	Description	Material
1	Ball	Inconel 718 / CC Coated
2	Seat	Inconel 718 / CC Coated
3	Spring	Inconel 718
4	Body	A182 F22
5	End Connection	A182 F22
6	Gasket	Inconel 718 / Gold Plated
7	Stem	A638 GR660
8	Stem Ball Bearing	Inconel 718 / CC Coated
9	Gland Flange	316SS / Molly Coated
10	Stem Packing	Expanded Graphite
11	Anti-Extrusion Ring	Braided Graphite w/ Inconel Wires
12	Metal Anti-Extrusion Ring	316SS
13	Pusher Seat	431SS / Nitrided
14	Stud	A193 GRB16
15	Nut	A194 GR4
16	Diffusion Plate	431SS

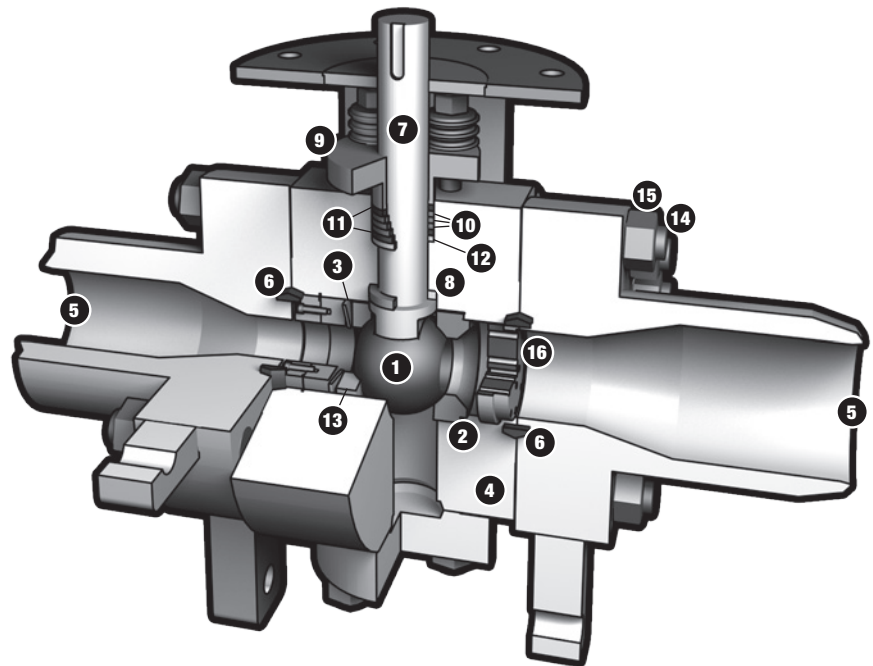

SD

Diffusion Plate to Breakdown Energy

Reducing Pressure While Maintaining Stem Integrity

This particular application requires a control on/off valve that opens during initial start-up to blow debris from the piping while pressure builds. Once the turbine is synchronized, the valve is closed. The valve is also used during shutdown to dump pressure. The valve is located just before the turbine stop valve in a line that leads to the condenser. Typical operating conditions of the application are 1000°F / 3800 psig (538°C / 262 bar) Dp.

The previous valve failed because the “Z” pattern design allowed the stem to be exposed during the initial turbulent flow. Often, the exposure would cut the stem after only one cycle. In addition, the flow caused tremendous wear in the elbow of the pipe.

MOGAS uses a diffusion plate to breakdown the energy developed when the valve is open. The diffusion plate is sized to be the equivalent of a 1.60-inch orifice. The replaceable diffusion plate has holes strategically placed to establish a fully developed flow in a minimum distance. This ensures less cavitation and erosion in the dead space of the pipe, located on the exit side of the valve.

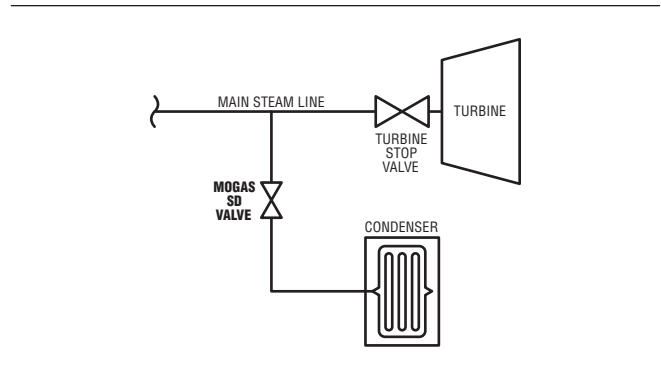

MOGAS uses a diffusion plate to breakdown energy.

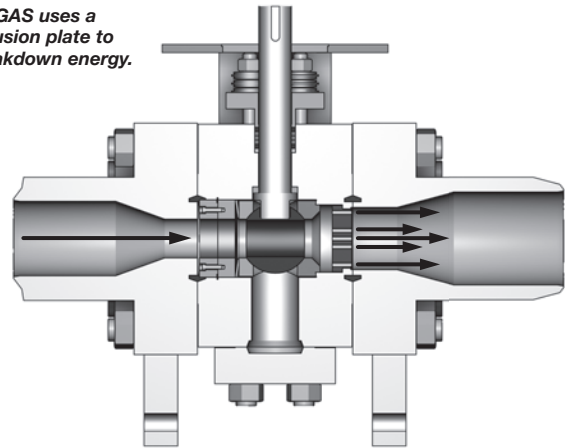

Temperature vs Pressure — Standard Class Ratings

Class	Mat'l.	Temperature (°F)																		
		-20 to 100	200	300	400	500	600	650	700	750	800	850	900	950	1000	1050	1100			
ASME 4500 Maximum Pressure (psig)	F22²	11250	11250	10925	10585	9965	9070	8825	8515	7970	7610	7305	6740	5795	4010	2625	1645			
Class	Mat'l.	Temperature (°C)																		
		-29 to 38	50	100	150	200	250	300	325	350	375	400	425	450	475	500	538	550	575	600
ASME 4500 Maximum Pressure (barg)	F22²	776	776	773	753	730	695	643	620	603	582	549	525	507	475	423	277	235	158	103

Temperature vs Pressure — Special Class Ratings

Class	Mat'l.	Temperature (°F)																		
		-20 to 100	200	300	400	500	600	650	700	750	800	850	900	950	1000	1050	1100			
ASME 4500 Maximum Pressure (psig)	F22²	11250	11250	10090	10915	10865	10815	10735	10605	10605	10605	10160	9000	7070	5015	3280	2055			
Class	Mat'l.	Temperature (°C)																		
		-29 to 38	50	100	150	200	250	300	325	350	375	400	425	450	475	500	538	550	575	600
ASME 4500 Maximum Pressure (barg)	F22²	776	776	774	764	753	750	747	744	738	731	731	731	708	641	535	346	293	197	129

²F22 not recommended for prolonged use above 1100°F / 593°C per ASME B16.34.

Conversions

Common Industry Conversions

Temperature	
Degrees F	Degrees C
-20	-29
0	-18
32	0
50	10
100	38
150	66
200	93
212	100
250	121
300	149
350	177
400	204
450	232
500	260
550	288
600	316
650	343
700	371
750	399
800	427
850	454
900	482
950	510
1000	538
1050	566
1100	593
1150	621
1200	649
1250	677
1300	704
1350	732
1400	760
1450	788
1500	816
1550	843
1600	871
1650	899
1700	927
1750	954
1800	982
1850	1010
1900	1038
1950	1066
2000	1093

Conversion Factor
°C = 5/9 (°F-32)

Pressure	
Pounds per Square Inch (psi)	Bar
1	0.069
2	0.138
3	0.207
4	0.276
5	0.345
10	0.689
20	1.379
30	2.068
40	2.758
50	3.447
100	6.895
150	10.342
200	13.789
300	20.684
400	27.579
500	34.474
600	41.369
700	48.263
800	55.158
900	62.053
1000	68.948
1500	103.421
2000	137.895
2500	172.369
3000	206.843
4500	310.264
6000	413.685
7500	517.107
9000	620.528
10500	723.949
12000	827.371
13500	930.792
15000	1034.214
17500	1206.583
20000	1378.951
22500	1551.320
25000	1723.689
27500	1896.058
30000	2068.427

Conversion Factor
1 psi = .0689655 bar

Linear	
Inch (in) (Fractions)	Millimeters (mm)
.125	3.18
.250	6.35
.375	9.53
.500	12.70
.625	15.88
.750	19.05
.875	22.23
Inches (in)	Centimeters (cm)
1	2.54
2	5.08
3	7.62
4	10.16
5	12.70
6	15.24
7	17.78
8	20.32
9	22.86
10	25.40
11	27.94
12	30.48
Feet (ft)	Meters (m)
1	0.3048
2	0.6096
3	0.9144
4	1.2192
5	1.524
6	1.8288
7	2.1336
8	2.4384
9	2.7432
10	3.048
15	4.572
20	6.096
25	7.62
30	9.144
35	10.668
40	12.192
45	13.716
50	15.24
60	18.288
70	21.336
80	24.384
90	27.432
100	30.48

Conversion Factor
1 inch = 25.4 millimeters

Weight	
Pounds (lb)	Kilograms (kg)
1	0.45
2	0.91
3	1.36
4	1.81
5	2.27
10	4.54
20	9.07
30	13.61
40	18.14
50	22.68
100	45.36
150	68.04
200	90.72
250	113.40
300	136.08
350	158.76
400	181.44
450	204.12
500	226.80
600	272.16
700	317.52
800	362.87
900	408.23
1000	453.59
1100	498.95
1200	544.31
1300	589.67
1400	635.03
1500	680.39
1600	725.75
1700	771.11
1800	816.47
1900	861.83
2000	907.19
2100	952.54
2200	997.90
2300	1043.26
2400	1088.62
2500	1133.98

Conversion Factor
1 pound = 0.4536 kilograms

Ask a MOGAS
Representative
today about how you
may benefit from a
customized Plant
Walkdown Program.

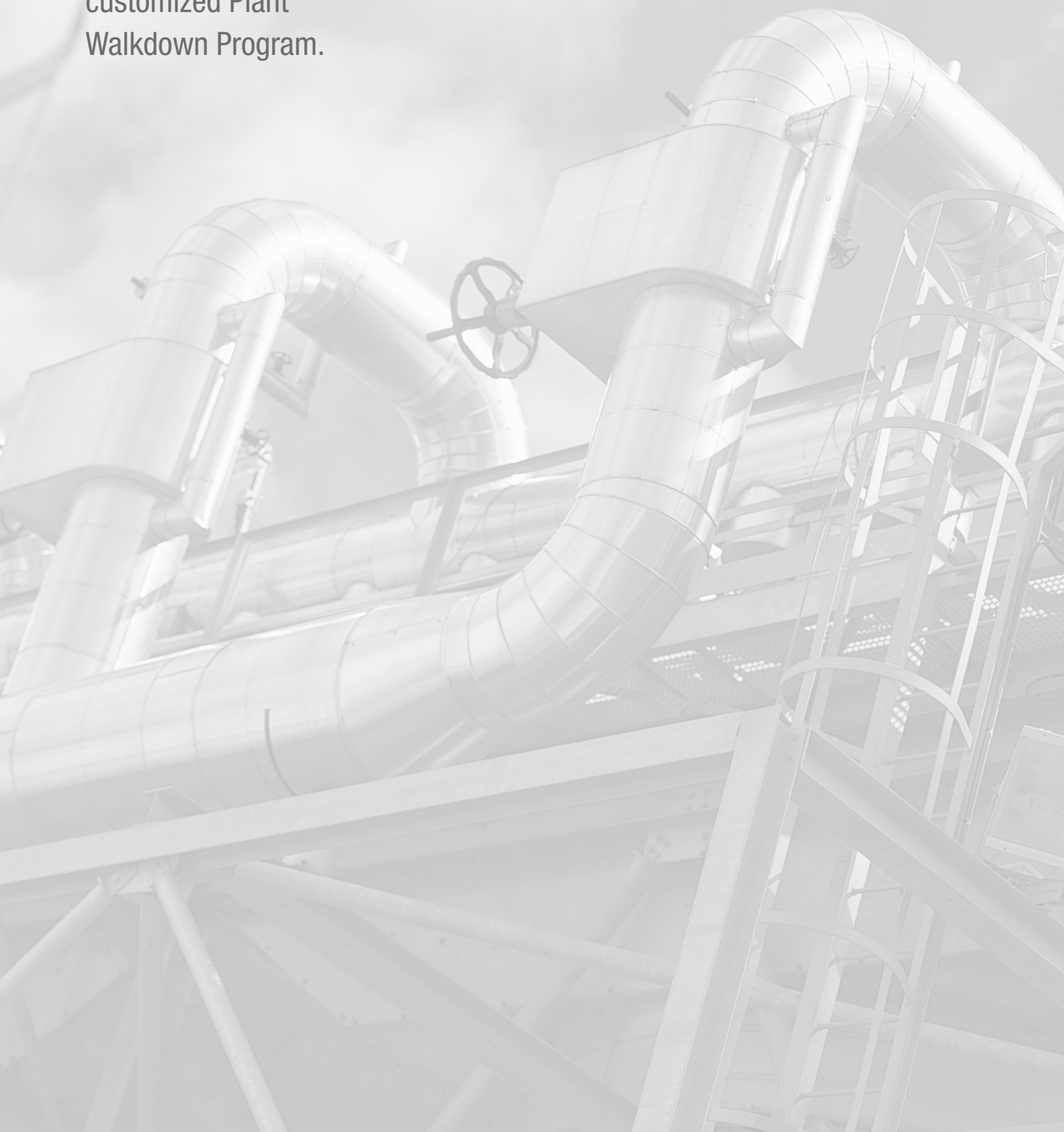

Severe Service

The MOGAS Definition

- Extreme temperatures
- High pressures
- Abrasive particulates
- Acidic products
- Heavy solids build-up
- Critical plant safety
- Large pressure differentials
- Velocity control
- Noise control

MOGAS Industries, Inc.

Headquarters

14330 East Hardy Street
Houston, TX, USA 77039-1405
Phone: +1.281.449.0291
Fax: +1.281.590.3412
E-mail: mogas@mogas.com

Europe

Phone: +44 (0)116.279.3367

China

Phone: +86 (0)10.84549478

Australia

Phone: +61 (0)8.9456.3533

**For other MOGAS locations
or a distributor in your area,
visit us online at
www.mogas.com**