



Fuels and Chemicals

## Scientific & Technical Report

---

FC-STR1

# Application of High Efficiency Liquid/Gas and Liquid/Liquid Coalescers in the Ammonia Industry

Presented at the 43<sup>rd</sup> Annual Safety in  
Ammonia Plants & Related Facilities Symposium

August 31 – September 3, 1998  
Charleston Place, Charleston, South Carolina

by

Thomas H. Wines, Pall Corporation USA  
Michel Farcy, Pall Europe



# Scientific & Technical Report

## Application of High Efficiency Liquid/Gas And Liquid/Liquid Coalescers in the Ammonia Industry

Thomas H. Wines, Pall Corporation USA and Michel Farcy, Pall Europe  
Presented at the 43<sup>rd</sup> Annual Safety in Ammonia Plants & Related Facilities Symposium  
Charleston Place, Charleston, South Carolina, August 31 – September 3, 1998

### Abstract

Oil contamination in liquid ammonia can cause various process, maintenance, and quality problems. The application of recent developments in high efficiency polymer fiber coalescer technology is

presented for liquid/gas and liquid/liquid separations. Commercial experience is presented along with economic considerations and process benefits.

### Introduction

Oil contamination in the synthesis and refrigeration of ammonia is a common phenomenon and can lead to adverse process effects. Oil contamination issues include off-specification product, heat exchanger fouling, catalyst bed poisoning and large clean-up projects of storage vessels. The source of the oil is generally from the lube oil used in inlet gas, synthesis gas, recycle gas, or refrigeration compressors. A generic schematic of an ammonia plant is presented in Figure 1 along with recommended locations for the installation of high efficiency coalescers for oil removal.

Carbon Dioxide (CO<sub>2</sub>), Methane (CH<sub>4</sub>) and Nitrogen (N<sub>2</sub>). Next the CO is changed to CO<sub>2</sub> in the Converter unit. Here oil contamination can lead to poisoning of the converter catalyst. The gas stream then passes through a liquid/gas adsorber which is usually hot potassium carbonate solution or alkanolamine solution for CO<sub>2</sub> removal. This is followed by a final methanation and drying step to produce the synthesis gas (mostly H<sub>2</sub>, N<sub>2</sub>).

The synthesis gas is then compressed to approximately 300 bar in the synthesis gas compressors. In most existing plants, the compressors are oil lubricated reciprocating piston compressors used to achieve the high pressure required for the ammonia synthesis reaction to occur. The use of these types of compressors will generally lead to oil contamination in the final ammonia product without protection and can also poison the synthesis reactor catalyst. The use of high efficiency, liquid gas coalescers is indicated downstream of the synthesis gas compressors. A portion of the gas leaving the synthesis reactor is recycled back to the inlet of the synthesis reactor after first being recompressed by the recycle compressors. The use of high efficiency liquid/gas coalescers is indicated downstream of the recycle gas compressor.

The ammonia gas (NH<sub>3</sub>) product leaving the synthesis reactor then passes through a refrigeration and condenser stage which liquefies the ammonia product before reaching refrigerated storage tanks

Figure 1  
Ammonia Plant

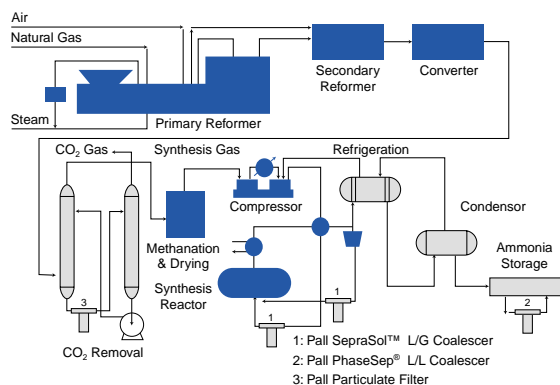

In the ammonia plant, natural gas and air are first compressed to about 40 bar and then enter the primary and secondary reformer. Lube oil can enter the inlet gas streams from these gas compressors and a high efficiency liquid/gas coalescer downstream of the inlet compressors is indicated. The gas stream leaving the reformers now contains mostly Hydrogen (H<sub>2</sub>), Carbon Monoxide (CO),

which are maintained at about 7 bar and 0°C. A schematic of the ammonia refrigeration process is presented in Figure 2. Oil contamination can lead to fouling of heat transfer surfaces such as the condenser and vaporizer in the refrigeration process. High efficiency liquid/liquid coalescers are indicated for the removal of the contaminant oil from the liquid ammonia stream prior to the storage tank.

Thus the removal of oil contamination can be accomplished in the gas streams at high pressures using liquid/gas coalescers or in the final liquid product using liquid/liquid coalescers.

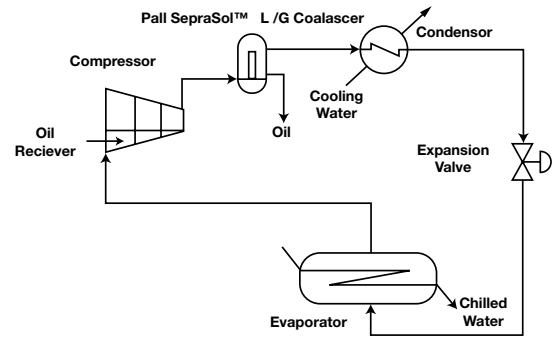

Figure 2: Ammonia Refrigeration Unit

## Coalescing Technology

### Liquid/Gas Coalescer System

The separation of liquid aerosol contamination with high efficiency liquid/gas coalescer cartridge systems has found widespread acceptance in refinery and gas plants in recent years for a number of applications (Pauley 1988, Schlotthauer 1991, Pauley 1991) including protection of compressors, turbo equipment, burner nozzles, amine and glycol contactors, molecular sieve beds, and hydrotreater catalyst beds. In the ammonia plant, the liquid/gas coalescers are used primarily to remove lube oil aerosols contamination downstream of compressors.

The growing trend to use more efficient liquid/gas coalescers has largely been the result of dissatisfaction with the traditional separation approaches of knock out vessels, centrifugal separators, mesh pads or vane separators which have not met the requirements for aerosol reduction. The primary rationale for the use of high efficiency coalescers is that significant aerosol contaminant exist in the plants that are in the sub micron and low micron size range (Brown 1994). High efficiency liquid/gas coalescers are generally constructed from glass fibers since this material allows for a fine porous structure with fiber diameters of a few microns. The small pore size is needed to achieve greater capture and separation of these fine aerosols.

Another important benefit of the liquid/gas coalescer is that this type of separation device can be

operated at significantly lower flow rates than design which means it has a high turn down ratio. This is due to the fact that the separation mechanisms are based primarily on diffusion and direct interception unlike vane separators and mesh pads which rely heavily on inertial separation principles. This allows the high efficiency liquid/gas coalescer systems a greater degree of flexibility and they can operate at peak performance even for high turn down ratios (reduced flow rates) which can occur during commonly encountered partial plant shutdowns and upset conditions. Generally, the high efficiency liquid/gas coalescers are used for inlet aerosol concentrations of less than 1,000 ppmw (0.1%) and are placed downstream of other bulk removal separators as the final stage. Outlet concentrations for these high efficiency liquid/gas coalescers are as low as 0.003 ppmw (Brown 1994, Williamson 1988).

The use of a surface treatment (Miller 1988) on Pall high efficiency vertical liquid/gas coalescers cartridge systems has been proven to significantly enhance performance by allowing higher flow rates or smaller housing diameters compared to untreated coalescers.

A Pall SepraSol™ vertical high efficiency liquid/gas coalescer system is depicted in Figure 3. The inlet gas with liquid aerosol contamination first enters at the bottom of the housing into a first stage knock out section. Here any slugs or larger size droplets (approximately > 300µm) are removed by

gravitational settling. The gas then travels upward through a tube sheet and flows radially from the inside of the cartridges through the coalescer medium to the annulus. The inlet aerosol distribution is in the size range of  $0.1\mu\text{m}$  -  $300\mu\text{m}$  and after passing through the coalescer medium is transformed to enlarged coalesced droplets in the size range of  $0.5$  -  $2.2$  mm. The advantage of flowing from the inside to outside of the coalescer cartridge is that the gas velocity can be more easily adjusted in the annulus by selecting the optimum housing diameter to prevent re-entrainment of coalesced droplets. As the gas leaves the coalescer cartridge and travels upward in the annulus it contributes to the total flow thereby increasing the annular velocity.

**Figure 3**  
Pall SepraSol™  
L/G Coalescer



Once the coalesced droplets are formed, they immediately drain vertically downward in the coalescer medium pack. The surface treatment greatly enhances this drainage and as a direct consequence of the treatment, the coalesced droplets are shielded from the upward gas flow in the annulus in most of the length of the coalescer cartridge. The coalesced droplets are first exposed to the annular gas flow when they appear on the external face of the coalescer medium pack at the bottom third of the coalescer cartridge. Once the coalesced droplets are released to the annular space they are subject to the force of the upward flowing gas. The trajectory of the coalesced droplets is modeled on a force balance between gravity settling and the drag force created by the gas flow past the droplets. This analysis leads to the calculation of a critical annular velocity for re-entrainment. The coalesced drops settle in the bottom of the housing into a collection sump that can be drained manually or equipped with level control for automatic drainage.

Due to the surface treatment, the maximum annular velocity at the top of the coalescer cartridge is found to be about three times greater than the value for an untreated coalescer. This allows for a given surface treated liquid/gas coalescer unit to handle about three times the gas capacity of an untreated coalescer system. Given the same process gas flow rate, the surface treated liquid gas coalescer system can be constructed with a smaller more economical vessel than the untreated coalescer system.

### Liquid/Liquid Coalescer System

Currently most ammonia producers use the storage tanks as settlers to remove contaminant oil from the final ammonia product. This method is not very efficient and on occasion the oil contamination concentration can reach levels of  $10$  -  $20$  ppm leaving the plant. The separation of oil from liquid ammonia using liquid/liquid coalescers is a relatively new field. The coalescer material must be able to withstand temperature down to  $-40^{\circ}\text{C}$  and be compatible with ammonia and oil as well as provide the required separation. Traditional liquid/liquid coalescers have used glass fiber media, which works well for emulsions that have interfacial tensions greater than  $20$  dyne/cm and for systems at ambient temperatures. Pall Corporation has developed new coalescer media, constructed with novel formulated polymers and fluoropolymers (Brown 1993, Wines 1997) that are effective for emulsions having interfacial tensions as low as  $0.5$  dyne/cm and for low temperature service. The interfacial tension between the oil and ammonia liquid has not been characterized due to the volatility of the ammonia and difficulty in using standard apparatus for interfacial tension measurements. The Pall liquid/liquid coalescer has produced clean ammonia with oil levels down to  $2$ - $3$  ppm in pilot scale tests.

A Pall PhaseSep® high efficiency liquid/liquid coalescer in the horizontal configuration is depicted in Figure 4. The system consists of a horizontal coalescer cartridge stage followed by a settling zone that relies on the difference in density for separation of the coalesced droplets. The fluid enters at the side of the housing and flows from the inside of the coalescer cartridges radially outward causing the enlargement or coalescing of the inlet dispersion into large droplets in the outlet stream.

The coalesced droplets then flow axially in the horizontal direction through a settling zone. The dispersed oil phase coalesced droplets settle downward by gravity and are collected in a sump located at the bottom of the housing. The purified liquid ammonia leaves at the top of the housing.

**Figure 4**  
Pall PhaseSep®  
L/L Coalescer

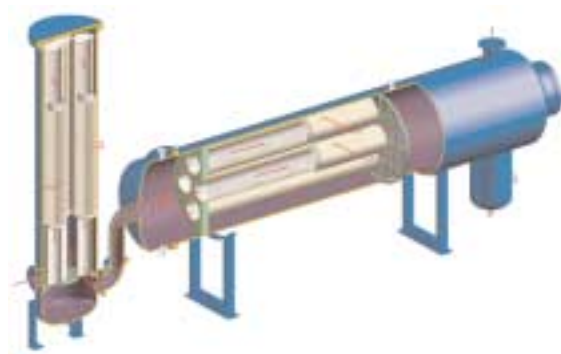

The liquid — liquid coalescing system operates in three stages: separation of solids, coalescence and separation of coalesced drops.

#### ***Separation of Solids***

Solids can increase the stability of an emulsion and removing solids can make coalescing easier. Generally, this step can be achieved by a separate cartridge filter system or by a regenerable backwash filter system for high levels of solids. In addition, the filtration stage protects the coalescer and increases service life.

#### ***Coalescence***

The next step in the process is the primary coalescence. In this stage, the pore dimensions begin with a very fine structure and then become more open to allow for void space for the coalescing droplets. In the primary coalescence zone, the inlet droplet dispersion containing fine droplets in the size range of 0.2 to 50 microns is transformed into a suspension of enlarged droplets in the size range of 500 to 5000 microns.

The coalescence mechanism can be described by the following steps:

1. droplet adsorption to fiber
2. translation of droplets to fiber intersections by bulk flow
3. coalescence of two droplets to form one larger droplet

4. repeated coalescence of small droplets into larger droplets at fiber intersections
5. release of droplets from fiber intersections due to increased drag on adsorbed droplets caused by bulk flow
6. repeat of steps 1-5 with progressively larger droplet sizes and more open media porosity

Based on this mechanism, we can predict that a number of factors will influence the coalescence performance. The specific surface properties of the coalescer fibers are critical in influencing the adsorption of droplets as well as the ultimate release after coalescing. There is a balancing act between increasing the attraction or adsorption characteristics of the fibers against the release mechanism which strong adsorption would inhibit. The necessary condition that droplet-fiber adsorption occur for coalescing has been supported by a number of sources (Jeater 1980, Basu 1993), although it is not universally accepted. The presence of significant levels or types of surfactants to cause the disarming phenomenon has been detected by measuring the interfacial tension between the aqueous and hydrocarbon phases. When surfactants are added to the water in hydrocarbon systems, the interfacial tension is decreased and in most cases, an interfacial tension of less than 20 dyne/cm was found to cause disarming of glass fiber coalescers. When specially formulated polymeric coalescer medium was used instead of glass fiber, disarming was not observed (Brown 1993, Wines 1997). The coalescing performance of a polymeric medium can be greatly enhanced by modification of surface properties that can not be accomplished by glass fiber medium.

#### ***Separation of Coalesced Droplets***

Once the droplets have been coalesced they are now assumed to be as large as possible for the given flow conditions. The separation stage is achieved in a settling zone which relies on the difference in densities between the coalesced droplets and the bulk fluid. The oil is then separated in a collection sump that can be manually drained on a periodic basis or equipped with an automatic level control and drain system. Estimation of the coalesced drop size and required settling zone are best determined through pilot scale tests at field conditions.

### **Zakłady Azotowe Pulawy, Poland**

#### ***Process Description***

Synthesis gas (H<sub>2</sub>, N<sub>2</sub>) is compressed to 320 bar by multistage lubricated reciprocating compressors and fed to the ammonia synthesis reactor. Downstream of the reactor, coolers and separators containing mesh pads are in service to remove liquid aerosol contamination from the ammonia gas. Zakłady Azotowe Pulawy was interested in reducing the oil content in the ammonia product that varied from 10 - 20 ppm, and as a result worked closely with Pall Corporation towards a solution.

#### ***Application Description and Experience***

Initially, a single Pall SeptraSol™ Liquid/Gas Coalescer system was installed in December 1994 on one of sixteen streams of the high pressure synthesis gas stream downstream of the compressors. The coalescer system contained 10 coalescer elements in a 580 mm (20 inch) diameter vessel and was operated at 40,000 Nm<sup>3</sup>/hr with a gas temperature of 50°C and pressure of 320 bar. The bottom stage of the coalescer housing was equipped with a mesh pad to act as a bulk removal stage for large aerosol droplet greater than 5µm in size. The process benefit realized was an ammonia product with no detectable oil contaminant (< 1 ppm) throughout an eighteen month trial. After this success, the remaining synthesis and recycle streams (16 total) in the plant were equipped with the combined mesh pad - Pall SeptraSol Liquid/Gas Coalescer Systems. This resulted in a total use of 280 Pall coalescer cartridges in sixteen vessels (10 - 16 coalescer elements per vessel) for process stream with flow rates ranging from 43,000 - 220,000 Nm<sup>3</sup>/hr and oil aerosol loadings from 4 - 30 ppm in the inlet gas. The additional Pall coalescer units have been operation since early 1997, and have experienced service lives varying from 12 - 18 months before the change out differential pressure of 350 mbar was reached.

#### ***Alternate Solutions Considered***

Before adopting the Pall Liquid/Gas Coalescers, Zakłady Azotowe Pulawy investigated a few alternate solutions. The use of an oil free compressor was considered but had the drawbacks of high capital investment for replacing the existing com-

pressors, and the likely possibility of higher maintenance costs as compared to the existing lubricated reciprocating compressors. Adsorption columns were also considered using either activated carbon or a molecular sieve. Some of the disadvantages for this type of system included: relatively high pressure drop across the beds, high energy costs for regeneration, need to monitor the bed saturation, possibility of crushed bed particles entraining and fouling the synthesis reactor, and contaminating final product.

#### ***Process Benefits***

The main process benefits are listed below:

1. The reduction in oil contamination in the final ammonia product to less than 1 ppm has completely eliminated any rejected ship loads leaving the plant.
2. The frequency of measuring the oil content of the final product ammonia was able to be reduced from once a day to once a week due to the consistent low level of oil in the ammonia after installation of the Pall coalescer system. This resulted in significant safety improvements in the plant from reducing exposure to the ammonia and also reduced the man power requirements.
3. The reduction in the oil content of the final product ammonia has enabled its sale into the fine chemical markets where purity is essential. The fine chemical market will purchase ammonia at \$200/metric ton which is considerably more than the fertilizer market which will spend from \$120 - \$150/metric ton. The total savings in this case will depend on the demand for ammonia as feed stock for the fine chemical market.
4. The current lubricated reciprocating compressors can be kept in service and not replaced with more expensive, maintenance intensive oil free compressors. Less expensive lubricating oil containing higher sulfur content can also be used in the existing compressors as it will not be contaminating the synthesis reactor and ammonia final product.

### **BP Chemicals, North Site, Grangemouth, UK**

#### ***Process Description***

An ammonia refrigeration unit is operated consisting of a compressor, condenser, expansion

valve, and evaporator. In the refrigeration cycle, the ammonia is vaporized in the evaporator and heat is being absorbed from the space being cooled. The ammonia vapor is next drawn into a motor driven compressor and elevated to high pressure. This causes the ammonia to be heated and the resulting superheated, high pressure ammonia gas is then condensed to liquid in a water cooled condenser. The liquid ammonia then flows through an expansion valve and the pressure and temperature are reduced to the conditions in the evaporator completing the cycle. Oil contamination was found to interfere with the refrigeration by causing fouling of heat transfer surfaces and resulting in a loss of cooling capacity.

#### ***Application Description and Experience***

In May, 1996, a Pall SeptraSol™ Liquid/Gas Coalescer system containing fifteen coalescer elements was installed downstream of the compressor package to reduce the fouling of heat transfer surfaces. The operating conditions were of system pressure of 10 bar gauge, a temperature of 86°C, and a flow rate of 1,400 actual m<sup>3</sup>/hr. The system was found to work effectively by BP Chemicals as oil was being collected and drained on a daily basis from the coalescer. After the Pall coalescers were installed, the level of oil in the ammonia loop has remained below the detection level of 1 ppm. Since the initial installation, the Pall coalescer elements have not been changed out and are continuing to operate effectively.

#### ***Process Benefits***

The main process benefits are listed below:

1. The heat removal capacity was improved from 10-20% due to the reduction in fouling of the heat transfer surfaces in the condenser and vaporizer.
2. The need to purchase additional costly refrigeration units (approximately \$1 million) was avoided by the increased refrigeration capacity for a relatively small investment of < \$100,000.

#### **Hydro Chemicals France, Division of Hydro Agri France**

#### ***Process Description***

Final product liquid ammonia is stored in cryogenic storage tanks and is loaded onto trucks at a flow rate of 60 metric tons/hour. The process

temperature varies between 0 - 3°C, and the pressure is 7 bar. Hydro Chemicals France initiated a test program with Pall Corporation to determine whether high efficiency liquid/liquid coalescers could reduce the oil content down to less than 5 ppm. The oil content of the ammonia was artificially varied to achieve a concentration from 8–15 ppm to challenge the test coalescer.

#### ***Application Description and Experience***

In January, 1998, a representative of Pall Corporation's Scientific and Laboratory Services Department conducted pilot scale tests using a ten inch length by 2 1/2 inch diameter test coalescer. The test was run on site at Hydro Chemicals France at the outlet of the cryogenic storage tanks just prior to the truck loading. The test program lasted over two weeks and the average effluent concentration of oil in the final product ammonia was 3 ppm at a test flow rate of 15 liters/minute. A solubility curve (Cyklis 1971) of oil in liquid ammonia at different temperatures is presented in Figure 5. The operating conditions at Hydro Chemicals France (0°C) indicates an oil solubility of 2 ppm. Therefore the Pall PhaseSep® Liquid/Liquid Coalescer was able to reduce the free oil level down to 1 ppm.

**Figure 5**  
Oil solubility  
in ammonia  
(See diagram  
on right side)

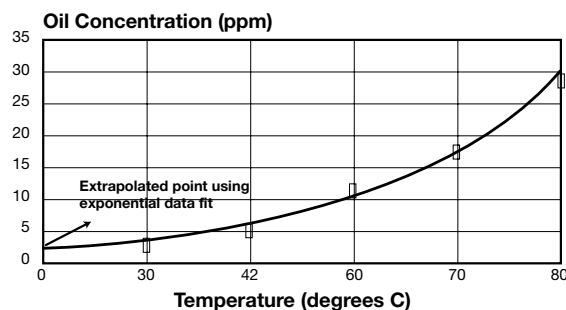

Data from Cyklis, 1971

#### ***Process Benefits***

Hydro Chemicals France has purchased a full scale Pall PhaseSep Liquid/Liquid Coalescer to be installed on a re-circulating loop on the storage tank to continuously purify the ammonia. The coalescer system includes a pre-filtration stage to protect the coalescers and will operate at a flow rate of 20 metric tons/hr using 20 coalescer elements in a 506 mm diameter housing. Expected benefits will be the reduction in the rejected product ratio and the ability to sell the ammonia as fine chemical grade for higher revenues.



## Literature Cited

1. Basu, S., "A Study on the Effect of Wetting on the Mechanism of Coalescence," *Journal of Colloid and Interface Science* 159, 68-76 (1993).
2. Brown, R. L., Wines, T. H., "Improve Suspended Water Removal From Fuels," *Hydrocarbon Processing*, December 1993, Vol. 72, No. 12, p. 95.
3. Brown, R. L., Wines, T. H., "Recent Developments in Liquid/Gas Separation Technology," Presented at the Laurence Reid Gas Conditioning Conference, Norman Oklahoma, February 28, 1994
4. Cyklis, D., Gorunov, N., "Solubility of Lubricating Oil in Liquid Ammonia," *Proceedings of State Institute of Nitrogen Industry* (Russia), 1971, Vol. 12, p.76
5. Jeater, P., Rushton, E., and Davies, G.A., "Coalescence in Fibre Beds," *Filtration & Separation*, March/April 1980, p. 129.
6. Miller, J. D., Koslow, R. R., Williamson, K.W., U.S. Patent 4,676,807, June 30, 1987; id. U. S. Patent 4,759,782, July, 1988
7. Pauley, C. R., Hashemi, R., and Caothien, S., "Analysis of Foaming Mechanisms in Amine Plants," Presented at the American Institute of Chemical Engineers Summer Meeting, Denver Colorado, August 22-24, 1988
8. Pauley, C. R., Langston, D. G., Betts, F., "Redesigned Filters Solve Foaming, Amine Loss Problems at Louisiana Gas Plant," *Oil & Gas Journal*, February 4, 1991
9. Schlotthauer, M. and Hashemi, R., "Gas Conditioning: A Key to Success in Turbine Combustion Systems Using Landfill Gas Fuel," Presented at the 14th Annual Landfill Gas Symposium GRCA / SWANA, San Diego, California, March 27, 1991
10. Williamson, K., Tousi, S., and Hashemi, R., "Recent Developments in Performance Rating of Gas / Liquid Coalescers," Presented at the First Annual Meeting of the American Filtration Society, Ocean City, Maryland, March 21-25, 1988



## Fuels and Chemicals

2200 Northern Boulevard  
East Hills, New York 11548-1289

888.873.7255 toll free  
516.484.5400 phone  
516.484.0364 fax

Visit us on the Web at [www.pall.com](http://www.pall.com)

### Select-A-FAX\* 800.664.7255

for the latest information delivered to any fax machine, anywhere in the world. This automatic system operates 24 hours a day, seven days a week. Call 1.516.942.0523 from outside the USA.

Pall Corporation has offices and plants throughout the world in locations including: Argentina, Australia, Austria, Belgium, Brazil, Canada, China, France, Germany, Hong Kong, India, Indonesia, Ireland, Italy, Japan, Korea, Malaysia, Mexico, the Netherlands, New Zealand, Norway, Poland, Puerto Rico, Russia, Singapore, South Africa, Spain, Sweden, Switzerland, Taiwan, Thailand, United Kingdom, United States, and Venezuela. Distributors are located in all major industrial areas of the world.

© Copyright 2001, Pall Corporation. Pall,  are trademarks of Pall Corporation. © Indicates a Pall trademark registered in the USA. \*Select-A-FAX is a registered trademark of CyberData, Inc.