

Liqui-Cel® Membrane Contactors Improve Water Quality and EDI Performance

Electrodeionization

Electrodeionization (EDI) is a widely used water treatment process. EDI technology is an electrochemical process that uses ion selective membranes and an electrical current to continuously remove ions from water. The process uses ion exchange resin to remove the ions from the feed stream, producing pure water. A DC current continuously regenerates the resin.

This technology operates under the same principles as conventional ion exchange resin technology with the added benefit of being a continuous process free of regeneration chemicals.

EDI Feed Water Requirements

In order to maximize the performance of an EDI unit, proper pretreatment is required. EDI equipment suppliers have different guidelines regarding feed water requirements but generally the specification can be summarized on the chart to the right.

Carbon Dioxide and Conductivity

When ion exchange is used to polish reverse osmosis membrane (RO) permeate, CO₂ needs to be controlled. This is true for conventional mixed bed ion exchange and EDI technologies. Excessive CO₂ is the leading cause of an EDI system not meeting design specifications. CO₂ gas dissociates in water to form HCO₃⁻ and CO₃²⁻. These ionic species will contribute to the total anionic load and should be added to the measured total. Overloading the anionic capacity of the EDI unit will lead to higher product conductivity and higher levels of weakly charged ions like boron and silica in the product water.

Feed water conductivity does not show a complete picture of the total ionic load in a water system. Conductivity measurement devices do not detect the full amount of weakly ionized species like carbon dioxide and silica. Suppliers have developed methods to quantify the total ionic load on the EDI system. Two methods are described below:

Equation 1

TEA as ppm CaCO₃ (Total exchangeable Ion) = TDS (ppm as CaCO₃, based on ionized species minus HCO₃⁻) + (ppm CO₂ * 1.14 * 1.7) + (ppm HCO₃⁻ as CaCO₃ * 1.7)

Equation 2

FCE as US/cm (Feed water Conductivity Equivalent) = (conductivity + ppm CO₂ * 2.66 + ppm SiO₂ * 1.94)

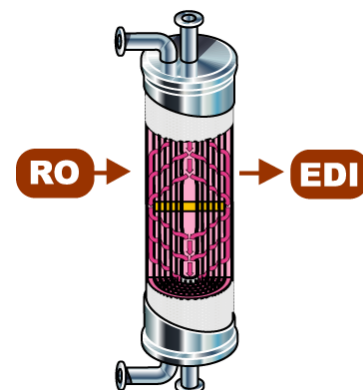

Typical EDI feed water specification

Feed water Constituent	EDI Feed Limit
PH	5-9
Conductivity (uS/cm)	<20
Hardness (as ppm CaCO ₃)	<1.0
TOC (ppm)	<0.5
Oxidizers (ppm)	ND
Metals (ppm)	<0.01 Fe, Mn
Silica (ppm)	<1.0
CO ₂ (ppm)	<5.0

Feed water Constituent	EDI Feed Limit
Total exchangeable Ion - TEA (as CaCO ₃) (eq1)	<25
Feed water conductivity Equivalent - FCE (US/cm) (eq2)	<20

These calculations show that the inlet CO₂ will contribute a significant anionic load on the EDI system. For example if the inlet water contains 5 ppm CO₂ and 1.5 ppm bicarbonate (HCO₃⁻) as CaCO₃ this will add 12.24 ppm as CaCO₃ to the TEA and 13.3 Us/cm to the FCE.

The most economical way to lower the load on the EDI is to remove a portion of the CO₂. This is illustrated below.

Anionic Load	5 ppm CO₂/ 1.5 ppm HCO₃	1 ppm CO₂/ 1.0 ppm HCO₃
TEA as CaCO ₃	12.2	3.6
FCE as Us/cm	13.3	2.66

EDI Pretreatment

EDI feed water pre-treatment is typically made up of softening and filtration using an RO system. These technologies can effectively remove particles, TOC, ions, and dissolved minerals from the water. Dissolved gases, however, are not effectively removed with these technologies.

Membrane Contactors

Liqui-Cel[®] Membrane Contactors are widely used to remove dissolved gas from water. Membrane Contactors are hydrophobic membranes that allow a gas and a liquid to contact each other without mixing. By adjusting the pressure and concentration of the gas in contact with the liquid, dissolved gasses can be removed from water. A typical membrane contactor system designed for CO₂ removal flows water on one side of the membrane; room air is drawn into the device under a vacuum on the other side. A schematic is shown to the right.

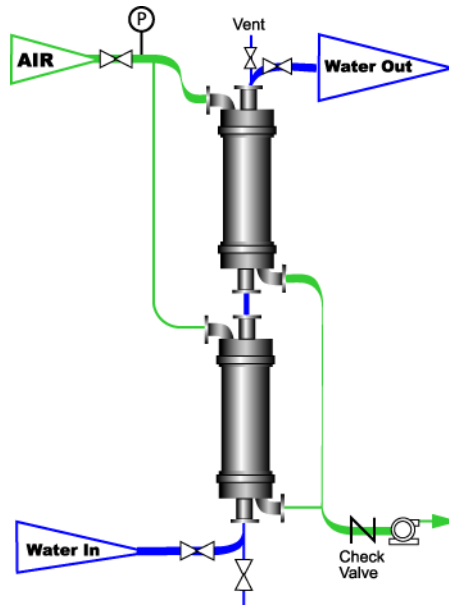

Membrane Contactors operate in-line under pressure and do not require surge tanks or transfer pumps. They can be installed downstream of the RO and upstream of the EDI unit to lower the CO₂ level to 1-5 ppm.

The Membrane Contactor system can be designed to lower the dissolved CO₂ to virtually any level required by the system. Additionally, as the ionic load is decreased, the power consumption of the EDI system can be reduced thus lowering the EDI operating costs. Furthermore, lowering the anionic load will improve the removal of the weakly charged anions like silica and boron.

Summary

Membrane Contactors are an important pretreatment process to an EDI unit. CO₂ can add significant ionic load to the EDI. Membrane Contactors are compact, effective devices for removing the dissolved CO₂ gas in the feed water to protect the unit from being overloaded with anions.

These two membrane-based technologies are leading the way for a cleaner, more environmentally friendly process for producing purified water.

For more information on using Liqui-Cel Membrane Contactors in your application, please visit us on-line at www.liqui-cel.com or call us at the numbers listed below.

References:

Michael Snow, Ph.D., VP, COO, Electropure Inc.
David F. Tessier, Ph.D, R&D Manager, E-Cell Corporation (a GE Business)

This product is to be used only by persons familiar with its use. It must be maintained within the stated limitations. All sales are subject to Seller's terms and conditions. Purchaser assumes all responsibility for the suitability and fitness for use as well as for the protection of the environment and for health and safety involving this product. Seller reserves the right to modify this document without prior notice. Check with your representative to verify the latest update. To the best of our knowledge the information contained herein is accurate. However, neither Seller nor any of its affiliates assumes any liability whatsoever for the accuracy or completeness of the information contained herein. Final determination of the suitability of any material and whether there is any infringement of patents, trademarks, or copyrights is the sole responsibility of the user. Users of any substance should satisfy themselves by independent investigation that the material can be used safely. We may have described certain hazards, but we cannot guarantee that these are the only hazards that exist.

Liqui-Cel, Celgard, SuperPhobic and MiniModule are registered trademarks and NB is a trademark of Membrana-Charlotte, A division of Celgard, LLC and nothing herein shall be construed as a recommendation or license to use any information that conflicts with any patent, trademark or copyright of Seller or others.

©2007 Membrana – Charlotte A Division of Celgard, LLC

(TB46 Rev1_10-05)

Membrana – Charlotte
A Division of Celgard, LLC
13800 South Lakes Drive
Charlotte, North Carolina 28273
USA
Phone: (704) 587 8888
Fax: (704) 587 8585

Membrana GmbH
Oehder Strasse 28
42289 Wuppertal
Germany
Phone: +49 202 6099 - 658
Phone: +49 6126 2260 - 41
Fax: +49 202 6099 -750

Japan Office
Shinjuku Mitsui Building, 27F
1-1, Nishishinjuku 2-chome
Shinjuku-ku, Tokyo 163-0427
Japan
Phone: 81 3 5324 3361
Fax: 81 3 5324 3369

MEMBRANA
MEMBRANA
Underlining Performance
www.membrana.com
www.liqui-cel.com

A **POLYPORE** Company