

Ministry of Mines and Metals, Iran National Iranian Copper Industries Co.



AHAR Consolidated Copper Mine Company



Type of process:
Copper Concentrator
with froth flotation

Primary Feed rate:
900 MTPH

Concentrate production:
30 MTPH

Commissioning year:
2004

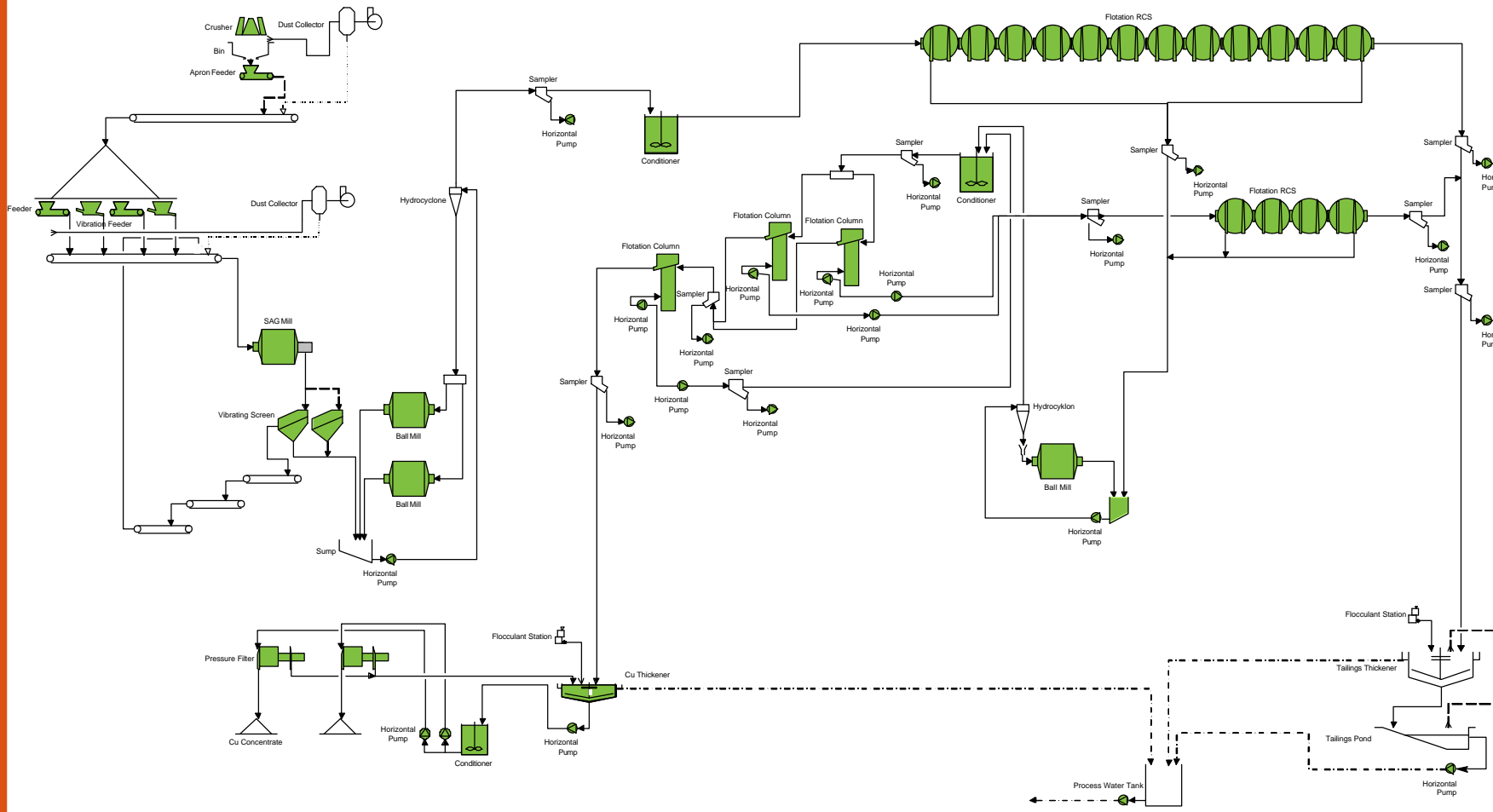

Scope of Supply:

Basic Engineering and Project Management

Main Process Equipment Metso Minerals:

- Primary Crusher, S-54-75
- Feeders and Screens
- Primary SAG mill, 9,75 m x 4,90 m, 2 x 4100 kW
- Secondary Ball mill 2 x 6,10 m x 9,30 m, 6000 kW
- Regrind Ball mill 4,00 m x 5,80 m, 1250 kW
- Rougher Flotation cells, 12 x RCS 130 m³
- 1st Cleaner Flotation cells, Column 4 m x 12 m
- 2nd Cleaner Flotation cell, Column 4 m x 9 m
- Cleaner Scavenger Flotation cells, 4 x RCS 50 m³
- Concentrate Thickeners, dia. 12 m
- Concentrate Pressure Filters, 2 x VPA 1,5 x 1,5 m with 46 chambers
- Tailings Thickeners, dia. 45 m
- Conditioners and surge tanks
- Slurry Pumps
- Slurry Piping

Spare and Wear parts for commissioning and 2 years of operation

Off-site and on-site training

Customized documentation and manuals

Erection and commissioning supervision

Main Sub-suppliers:

Electrical equipment and process instrumentation,

Electrical equipment, ABB

Process instrumentation, Endress+Hauser

Air compressors, Atlas Copco

Air blowers, Hick Hargraves

Hydro cyclones, KREBS

Rock Breaker, Sandvik Tamrock

Slurry valves, various suppliers

Metering pumps, Bran & Lubbe

Flocculant stations, TOMAL

Analyzer and samplers, Thermo Gamma-Metrics

Scrap magnets and Metals detectors, Eriez Magnetics

Consumables (flotation reagents and lubricants) for commissioning and initial operation, various suppliers