



# A Design Study in Steel Castings Steel Plates in Oil Rig Blowout Preventer Valves

## Design Study Outline

### Introduction

### Design for Performance

Alloy Selection

Radii and Stress Reduction

### Design for Production

Mold Method

Orientation and Cores

Controlling Solidification

### Quality Assurance

### Lessons Learned and Summary



# Start the Design Study !



### Acknowledgment --

*The metalcasting design studies are a joint effort of the  
Steel Founders' Society of America and the American Foundry Society.*

*Project funding was provided by the American Metalcasting Consortium Project, which  
is sponsored by the Defense Logistics Agency, Attn: DLSC-T, Ft. Belvoir, VA, 22060-6221*



[Return to  
SFSA  
Home Page](#)

Copyright 2003 by the Steel Founders' Society of  
America All rights reserved.  
Address comments to: [blairr@sfsa.org](mailto:blairr@sfsa.org)  
Last Modified: April, 2003 by STG

*In cooperation with  
[Pacific Steel Castings](#)*



# Blowout Preventer(BOP) - Application

- A blowout preventer (BOP) is a high pressure safety valve system at the top of the well head which stops uncontrolled fluid/gas flow in the wellbore.
- There are two types of BOP valves -- annular and ram.
  - One advantage the annular blowout preventer has over ram-type blowout preventers is the ability to seal on a variety of pipe sizes.

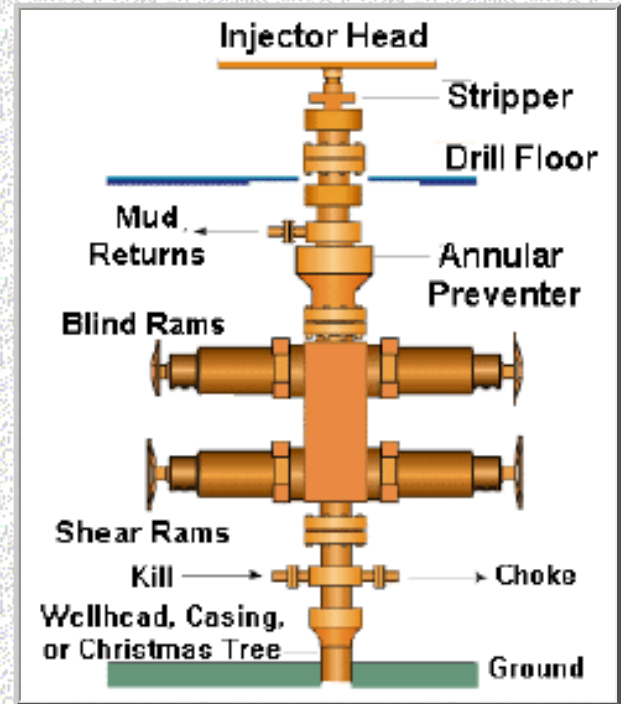

[Back](#) [Next](#)

2



[Return to SFSA Home Page](#)

Copyright 2003 by the Steel Founders' Society of America All rights reserved.  
Address comments to: [blairr@sfsa.org](mailto:blairr@sfsa.org)  
Last Modified: April, 2003 by STG



[Page 1](#)

In cooperation with  
[Pacific Steel Castings](#)



## BOP Seal Ring Function

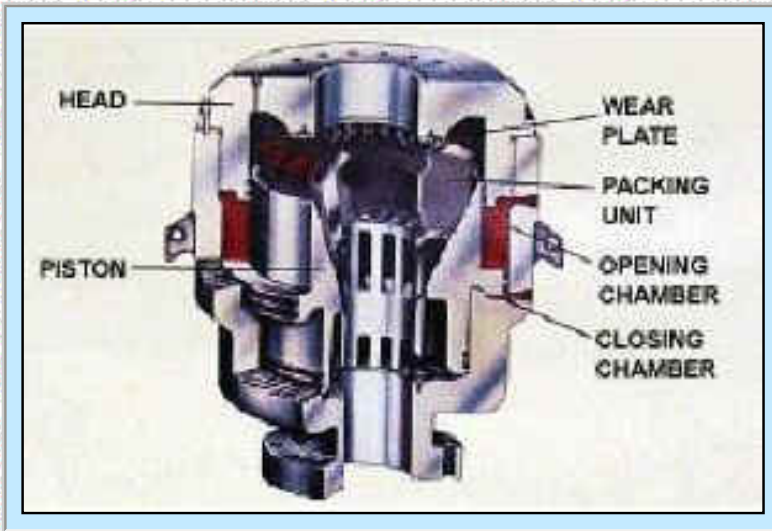

In the annular type of BOP valve, the sealing element is an elastomeric packing ring which forms the conforming seal.

- The packing is mechanically squeezed inward to seal on either pipe (drill collars, drill pipe, casing, or tubing) or the open hole.

*The packing ring is compressed by the upward wedging action of the hydraulically actuated piston.*

\*\*\*\*\*

*The compressed ring shuts off over-pressure gas and oil flow.*



[Back](#) [Next](#)

3



[Return to SFSA Home Page](#)

Copyright 2003 by the Steel Founders' Society of America. All rights reserved.  
 Address comments to: [blairr@sfsa.org](mailto:blairr@sfsa.org)  
 Last Modified: April, 2003 by STG



[Page 1](#)

In cooperation with  
[Pacific Steel Castings](#)





## Insert Plates -- Description

**A critical component in the packing ring are the multiple steel insert plates which reinforce the elastomeric ring.**

- The plates mechanically strengthen and stiffen the elastomeric seal ring and transfer the forces from the forcing piston to the face of the seal ring.
- The number, dimensions, and weight of the steel plates in a given valve depend on the size and configuration of the BOP, which are produced in a wide range of sizes and capacities.



Depending on size, a BOP valve can use 10 to 30 insert plates in the seal ring



[Back](#) [Next](#)



[Return to SFSA Home Page](#)

Copyright 2003 by the Steel Founders' Society of America All rights reserved.  
Address comments to: [blairr@sfsa.org](mailto:blairr@sfsa.org)  
Last Modified: April, 2003 by STG



[Page 1](#)

In cooperation with [Pacific Steel Castings](#)





## Insert Plates -- Description

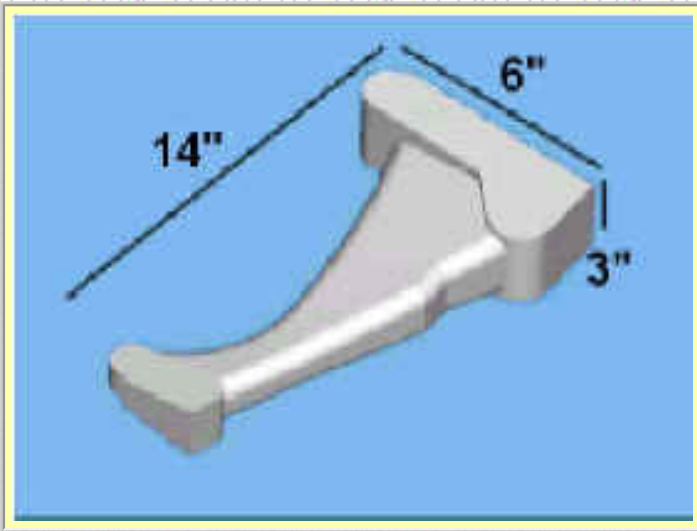

A typical steel insert plate is an angled flat steel bar with thickened flanges on the two ends.

Pacific Steel produces more than 3,000 of these steel plate castings in various configurations every year for the drilling equipment industry.

- A typical plate is 14" long and 6" wide. The center of the bar is 2 inches thick while the end flanges are 3 inches thick.
- A typical plate has a weight of 25 pounds, depending on size.



[Back](#) [Next](#)

5



[Return to SFSA Home Page](#)

Copyright 2003 by the Steel Founders' Society of America All rights reserved.  
Address comments to: [blairr@sfsa.org](mailto:blairr@sfsa.org)  
Last Modified: April, 2003 by STG



[Page 1](#)

In cooperation with  
[Pacific Steel Castings](#)





## Insert Plates -- Requirements

The nominal performance requirements for the insert plates are:

- Yield strength of 85 ksi.
- Brinell Hardness of 235HB
- 0.03" tolerance on machined surfaces.
- 500-900 RMS surface finish on as-cast surfaces.



[Back](#) [Next](#)



[Return to SFSA Home Page](#)

Copyright 2003 by the Steel Founders' Society of America. All rights reserved.  
Address comments to: [blairr@sfsa.org](mailto:blairr@sfsa.org)  
Last Modified: April, 2003 by STG



[Page 1](#)

In cooperation with [Pacific Steel Castings](#)





A Design Study in Steel Castings - Steel Plates in BOP Valve

## The Casting Design Issues



The casting design engineers at Pacific Steel Castings of Berkeley, CA focussed on three imperatives --

- *Design for Performance*
- *Design for Production*
- *Design for Cost*

**Critical Casting Design Issues** --The requirements for performance, castability/manufacturability, and cost are closely interconnected. Four casting design issues played a major role in meeting the three design imperatives.

- Select the [steel composition](#) that meets the mechanical property requirements.
- Design the [critical features](#) for stress reduction and metal flow.
- Choose a [molding system](#) that meets tolerance and cost targets.
- Design an [orientation and rigging system](#) that minimizes shrinkage in the castings.



[Back](#) [Next](#)

7



[Return to SFSA Home Page](#)

Copyright 2003 by the Steel Founders' Society of America. All rights reserved.

Address comments to: [blairr@sfsa.org](mailto:blairr@sfsa.org)

Last Modified: April, 2003 by STG



[Page 1](#)

In cooperation with [Pacific Steel Castings](#)





A Design Study in Steel Castings - Steel Plates in BOP Valve

## Alloy Selection

A fundamental design decision is the selection of a steel alloy that meets the performance requirements at a cost-effective price.

For the steel insert plates, the mechanical requirements are:

- 85 ksi yield strength
- 235 Brinell hardness

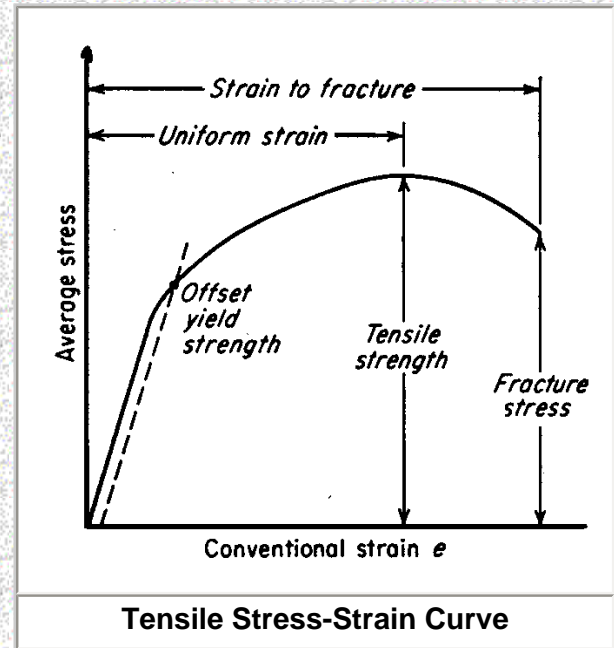

[Back](#) [Next](#)

8



[Return to SFSA Home Page](#)

Copyright 2003 by the Steel Founders' Society of America All rights reserved.

Address comments to: [blairr@sfsa.org](mailto:blairr@sfsa.org)

Last Modified: April, 2003 by STG



[Page 1](#)

In cooperation with  
[Pacific Steel Castings](#)







A Design Study in Steel Castings - Steel Plates in BOP Valve

## Alloy Selection

*Based on the performance requirements, a Nickel-Chrome-Moly low alloy steel (AISI-SAE 8627) was chosen, based on the mechanical requirements at the best alloy cost.*



The 8627 alloy has a nominal composition of--

- 0.24- 0.31 Carbon
- 0.55- 0.70 Nickel
- 0.35- 0.60 Chromium
- 0.15- 0.25 Molybdenum

The 8627 alloy has the following typical mechanical properties, depending on heat treatment-

- Yield strength = 60-160 ksi
- Hardness = 175-360 Brinnell



[Back](#) [Next](#)

9



[Return to SFSA Home Page](#)

Copyright 2003 by the Steel Founders' Society of America All rights reserved.

Address comments to: [blairr@sfsa.org](mailto:blairr@sfsa.org)

Last Modified: April, 2003 by STG



[Page 1](#)

In cooperation with  
[Pacific Steel Castings](#)



## Reducing Stress Concentrations

- One of the benefits of casting is the design flexibility in shaping features in the casting.
- Two important design principles in casting are --
  - Round corners and edges generously to reduce stress concentrations.
  - Reduce the size of isolated thick sections or provide gradual transitions between sections of different thickness.

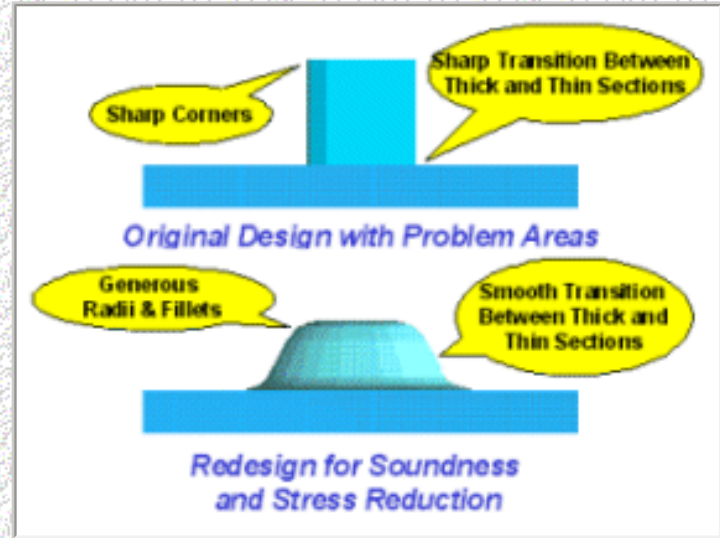

The casting engineer will always review the component design looking for those features which have:

-- sharp corners and fillets

-- isolated, thick sections.



[Back](#) [Next](#)

10



[Return to SFSA Home Page](#)

Copyright 2003 by the Steel Founders' Society of America All rights reserved.  
 Address comments to: [blairr@sfsa.org](mailto:blairr@sfsa.org)  
 Last Modified: April, 2003 by STG



[Page 1](#)

In cooperation with  
[Pacific Steel Castings](#)





A Design Study in Steel Castings - Steel Plates in BOP Valve

## Reducing Stress Concentrations

A review of the first design of the insert plate showed a number of areas where generous radii and filleting would reduce stress and improve castability.

The drawing to the right highlights three features that were considered for rounding and stress reduction

- [Feature A](#) -- Nose of the Header
- [Feature B](#) -- Interior Edge of the Bar
- [Feature C](#) -- Base of the Foot

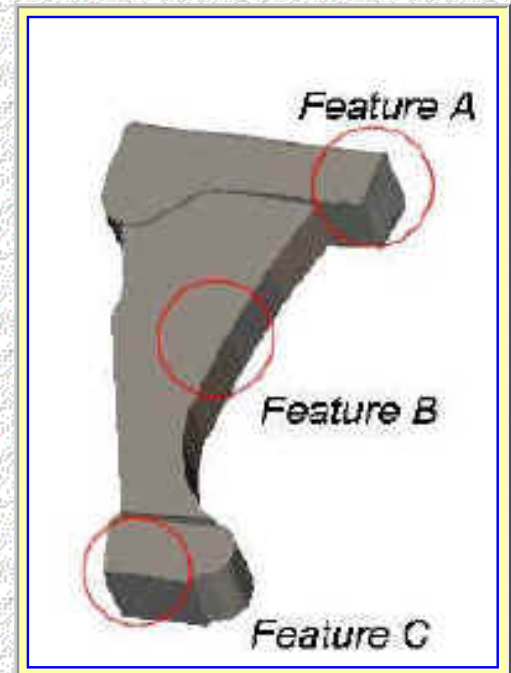

Choose which features would benefit from a generous radius --  
**Feature [A](#), [B](#), or [C](#).**



[Back](#)

Select a  
Feature

11



[Return  
to SFSA  
Home  
Page](#)

Copyright 2003 by the Steel Founders' Society of America All rights reserved.

Address comments to: [blairr@sfsa.org](mailto:blairr@sfsa.org)

Last Modified: April, 2003 by STG



[Page 1](#)

In cooperation with  
[Pacific Steel  
Castings](#)



## Feature A - Nose of the Header



- A generous radius on the nose of the header will eliminate two sharp corners, reduce stress and avoid corner defects in the casting, which are produced by sharp, weak corners in the sand mold.

*The nose of the header should be radiused.*

*Go to the [Next Design Issue](#) or  
[Go Back for Another Choice!](#)*



[Back](#) [Next](#)

12



[Return  
to SFSA  
Home  
Page](#)

Copyright 2003 by the Steel Founders' Society of America All rights reserved.  
Address comments to: [blairr@sfsa.org](mailto:blairr@sfsa.org)  
Last Modified: April, 2003 by STG



[Page 1](#)

In cooperation with  
[Pacific Steel  
Castings](#)



## The Molding Methods

**Pacific Steel uses three types of molding methods.**

### GREEN SAND MOLD

Moist, clay-bonded sand is tightly packed around a wood or metal pattern in mold boxes. The pattern halves are removed, and the mold is assembled with or without cores.

### AIR-SET SAND MOLD

Chemically bonded sand is packed around a wood or metal pattern in mold boxes. At room temperature, the sand molds become rigid. Pattern halves are removed and the mold is assembled with or without cores.

### SHELL MOLD

Resin-coated sand is applied to heated metal patterns forming shell-like mold halves. The shell halves are bonded together with or without cores.



Sand Mold



Shell Mold



[Back](#) [Next](#)

15



[Return to SFSA Home Page](#)

Copyright 2003 by the Steel Founders' Society of America. All rights reserved.  
Address comments to: [blairr@sfsa.org](mailto:blairr@sfsa.org)  
Last Modified: April, 2003 by STG



[Page 1](#)

In cooperation with  
[Pacific Steel Castings](#)





A Design Study in Steel Castings - Steel Plates in BOP Valve

## The Molding Methods

Each of the three molding methods has relative capabilities, advantages, and costs, as shown in the table below.

|   | Target    | Shell-Mold | Air-Set Sand | Green Sand |
|---|-----------|------------|--------------|------------|
| As-cast dimensional tolerance across 1" | +/- 0.060 | +/- 0.030  | +/- 0.060    | +/- 0.060  |
| Nominal surface finish (RMS)            | 500-900   | 300-500    | 500-900      | 500-900    |
| Minimum Section Thickness               | 0.50 inch | 0.25 inch  | 0.25 inch    | 0.25 inch  |
| Intricacy of detail                     | Fair      | Very Good  | Good         | Fair       |
| Tool/Pattern Cost                       | Low       | High       | Low          | Low        |
| Mold Material Cost                      | Low       | Medium     | Medium       | Low        |
| Tool Lead Time                          | Short     | Long       | Short        | Short      |

Given the as-cast tolerance and finish requirements, the level of detail, and the low cost driver for the insert plates, choose an appropriate molding method --

**SHELL MOLD, AIR-SET SAND, GREEN SAND**



Choose a method

[Back](#)

16



[Return to SFSA Home Page](#)

Copyright 2003 by the Steel Founders' Society of America All rights reserved.  
Address comments to: [blairr@sfsa.org](mailto:blairr@sfsa.org)  
Last Modified: April, 2003 by STG



[Page 1](#)

In cooperation with  
[Pacific Steel Castings](#)



# Shell Molding



Metal Patterns for Shell Molds

- Shell molding significantly exceeds the baseline requirements for tolerance, surface finish, and detail level for the insert plate.
- But the high costs and long lead time for the metal tool for shell molding are not justified in this case, where the tolerance and finish requirements are generous.

*Shell molding is not the best choice  
[Go back and select another process.](#)*



[Back](#)



[Return to SFSA Home Page](#)

Copyright 2003 by the Steel Founders' Society of America All rights reserved.  
Address comments to: [blairr@sfsa.org](mailto:blairr@sfsa.org)  
Last Modified: April, 2003 by STG



[Page 1](#)

In cooperation with  
[Pacific Steel Castings](#)





# Air Set Sand Molding



Metal Pouring into the Mold

- Air-set sand molding has a moderately tighter tolerance and smoother surface finish capability, compared to the green sand.
- But the extra cost for the chemically bonded sand in the air-set mold is not justified in this case, where the tolerance and finish requirements are generous.

*Air Set sand is not the best choice  
[Go back and select another process.](#)*



[Back](#)



[Return to SFSA Home Page](#)

Copyright 2003 by the Steel Founders' Society of America All rights reserved.  
Address comments to: [blairr@sfsa.org](mailto:blairr@sfsa.org)  
Last Modified: April, 2003 by STG



[Page 1](#)

In cooperation with  
[Pacific Steel Castings](#)





## Green Sand Molding

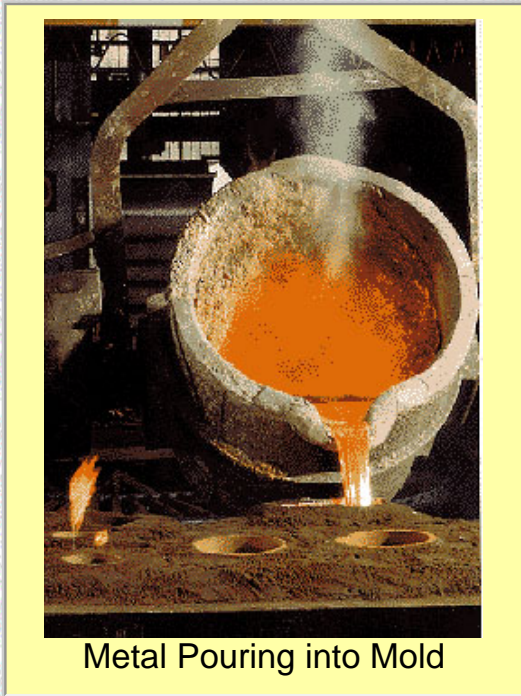

- Green sand molding can meet the baseline requirements for the insert plate for tolerance, surface finish, and detail level.
- Green sand molding has lower costs for mold material compared to air-set sand and lower pattern and material cost compared to shell molding.

*Green sand molding is the best choice.  
[Go to the Next Design Issue!](#)*



[Back](#) [Next](#)



[Return to SFSA Home Page](#)

Copyright 2003 by the Steel Founders' Society of America All rights reserved.  
Address comments to: [blairr@sfsa.org](mailto:blairr@sfsa.org)  
Last Modified: April, 2003 by STG



[Page 1](#)

In cooperation with  
[Pacific Steel Castings](#)



## Orientation in the Mold

In mold design, the orientation of the part in the mold is an important factor in producing a sound casting. The part should be oriented in the mold, so that --

- The vertical rise and metal splashing are minimized.
- The parting line lies in the major plane of the component.

The foundry engineer has two options for orienting the plate in the mold

- [Option A](#) - Vertical Orientation
- [Option B](#) - Horizontal Orientation

*Which orientation will minimize vertical rise and splashing in the mold and give the simplest parting line -*

*Vertical or Horizontal?*

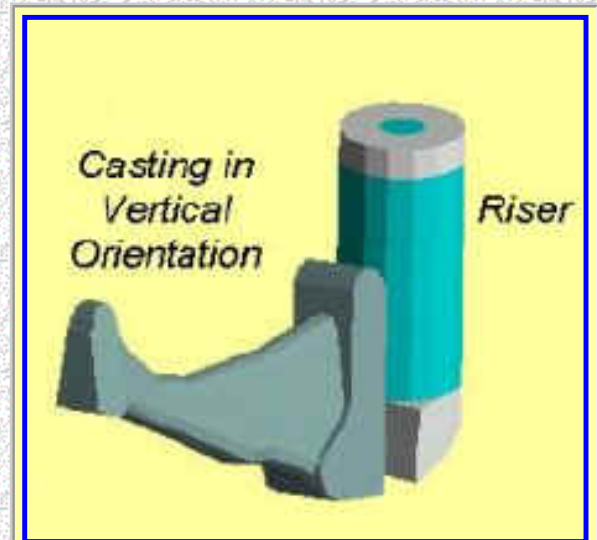

[Back](#)

Choose an Orientation

20



[Return to SFSA Home Page](#)

Copyright 2003 by the Steel Founders' Society of America. All rights reserved.  
 Address comments to: [blairr@sfsa.org](mailto:blairr@sfsa.org)  
 Last Modified: April, 2003 by STG



[Page 1](#)

In cooperation with  
[Pacific Steel Castings](#)



## Vertical Orientation

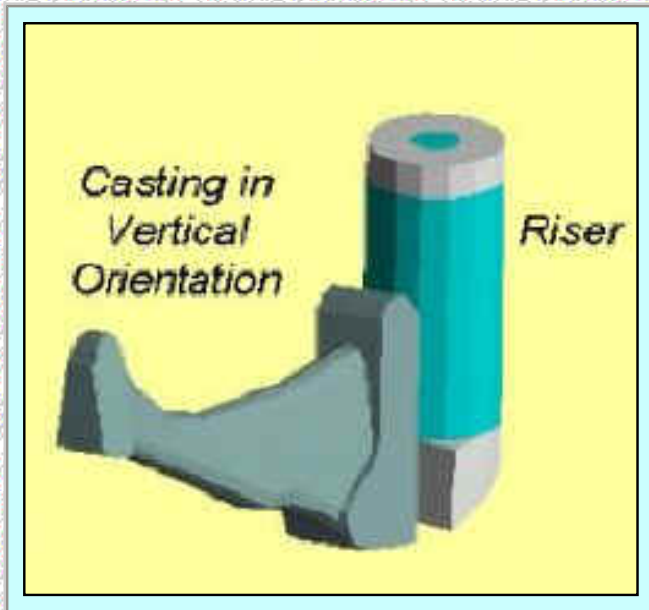

In the vertical orientation, metal flow into the plate will be restricted by the vertical rise into the mold cavity, producing turbulence and requiring a taller riser.

- The riser will also have difficulty feeding molten metal into the head and foot of the casting which will tend to produce shrinkage there.
- The parting line will be irregular and offset to accommodate the angle of the plate in the mold.

**The vertical orientation is not the best approach.  
[Go back and choose another orientation.](#)**



[Back](#)

21



[Return to SFSA Home Page](#)

Copyright 2003 by the Steel Founders' Society of America All rights reserved.  
 Address comments to: [blairr@sfsa.org](mailto:blairr@sfsa.org)  
 Last Modified: April, 2003 by STG



[Page 1](#)

In cooperation with  
[Pacific Steel Castings](#)



## Horizontal Orientation



- A horizontal orientation will give the smoothest flow and best fill into the mold.
- The riser will feed molten metal easily into the head and foot of the casting.
- The parting line will be straight and oriented along the edges of the plate.

**The horizontal orientation is the better approach.**  
**Go to the next design topic**



[Back](#) [Next](#)

22



[Return to SFSA Home Page](#)

Copyright 2003 by the Steel Founders' Society of America All rights reserved.

Address comments to: [blairr@sfsa.org](mailto:blairr@sfsa.org)

Last Modified: April, 2003 by STG



[Page 1](#)

In cooperation with  
[Pacific Steel Castings](#)



## Cores

Cores are preformed sand aggregates placed in the mold to shape the interior or a part of a casting that cannot be shaped by the pattern.

- In the insert plate, there is no feature that has to be formed by a core.
- But a core was used in the mold, so that two plates can be formed in a single casting pour.
- The drawing to the right shows how a core was used to separate and form two plates in a single mold.

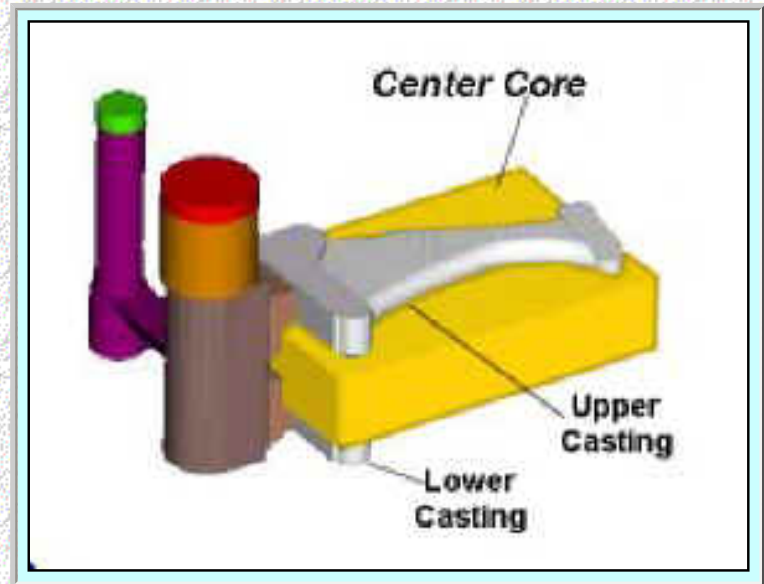

[Back](#) [Next](#)

23



[Return  
to SFSA  
Home  
Page](#)

Copyright 2003 by the Steel Founders' Society of America. All rights reserved.  
Address comments to: [blairr@sfsa.org](mailto:blairr@sfsa.org)  
Last Modified: April, 2003 by STG



[Page 1](#)

In cooperation with  
[Pacific Steel  
Castings](#)



## Controlling Solidification

A critical casting process design issue is how the solidification of the metal is controlled in the mold. Controlled solidification is necessary to eliminate isolated hot spots and to prevent shrinkage in the body of the casting.

Two methods of controlling solidification are:

- Using “chill blocks” to locally increase the rate of heat removal in heavier sections and accelerate solidification
- Positioning risers to act as reservoirs to feed metal into heavier sections during solidification.

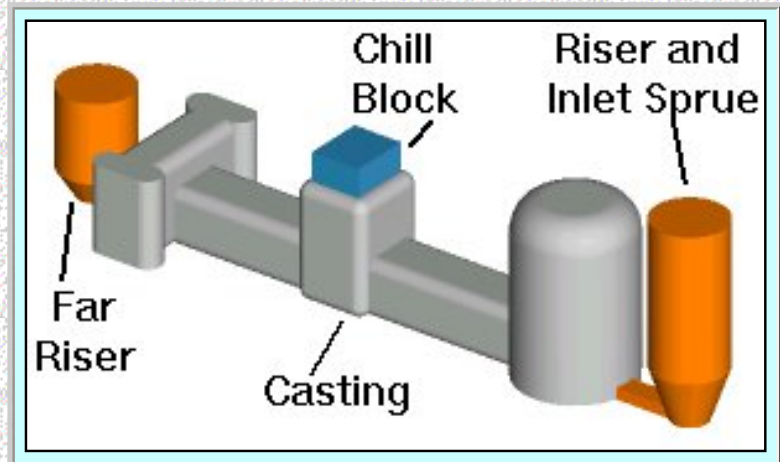

[Back](#) [Next](#)

24



[Return to SFSA Home Page](#)

Copyright 2003 by the Steel Founders' Society of America. All rights reserved.  
Address comments to: [blairr@sfsa.org](mailto:blairr@sfsa.org)  
Last Modified: April, 2003 by STG



[Page 1](#)

In cooperation with  
[Pacific Steel Castings](#)



A Design Study in Steel Castings - Steel Plates in BOP Valve

## Controlling Solidification

A critical area in the plate is the end bar on the foot of the casting.

Two approaches were considered for controlling solidification in the foot:

- [Approach A](#) -- One riser at the head of the casting with a chill block on the foot.
- [Approach B](#) -- Two risers -- one at the head and one at the foot of the casting.

Choose the Approach

([Approach A](#) or [B](#))

which will be more effective in reducing shrinkage in the foot of the casting.

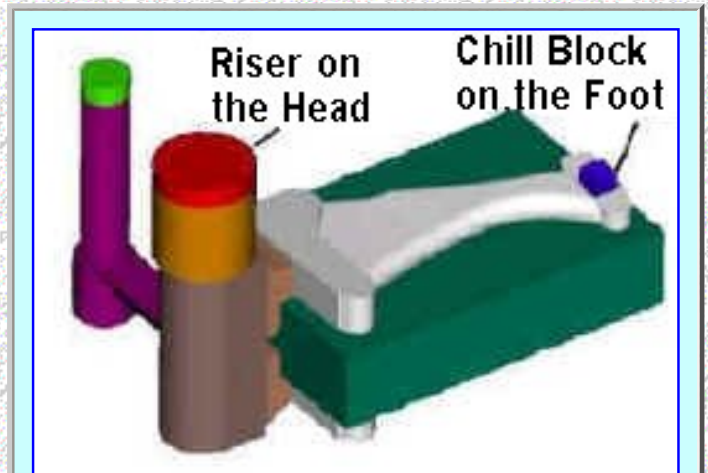

Approach A- Chill on Foot

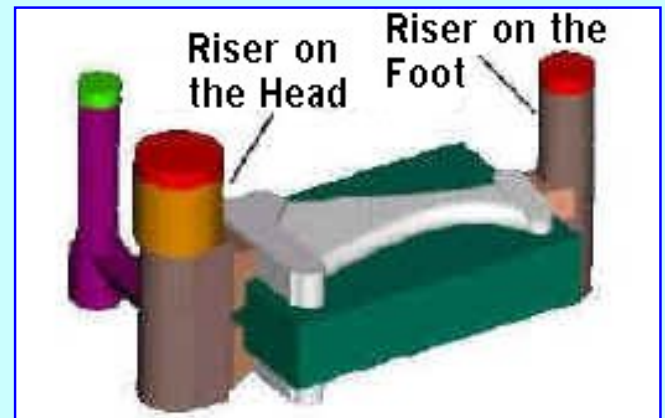

Approach B - Riser on Foot



Choose an approach

[Back](#)

25



[Return to SFSA Home Page](#)

Copyright 2003 by the Steel Founders' Society of America All rights reserved.

Address comments to: [blairr@sfsa.org](mailto:blairr@sfsa.org)

Last Modified: April, 2003 by STG



[Page 1](#)

In cooperation with

[Pacific Steel Castings](#)



## A Design Study in Steel Castings - Steel Plates in BOP Valve

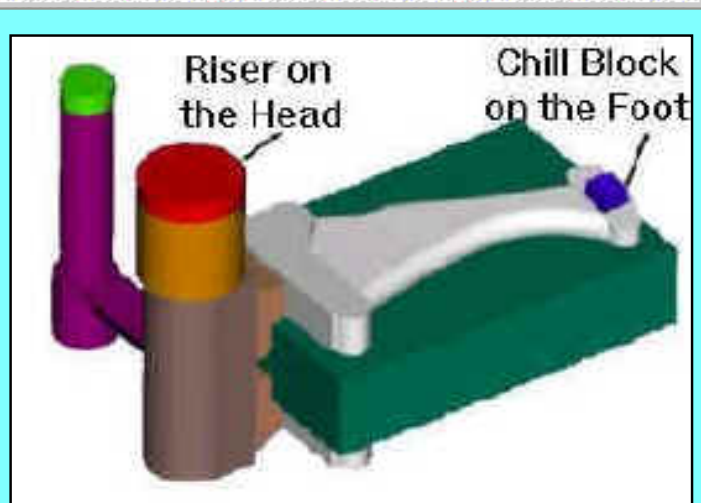

Chill Block on the Foot

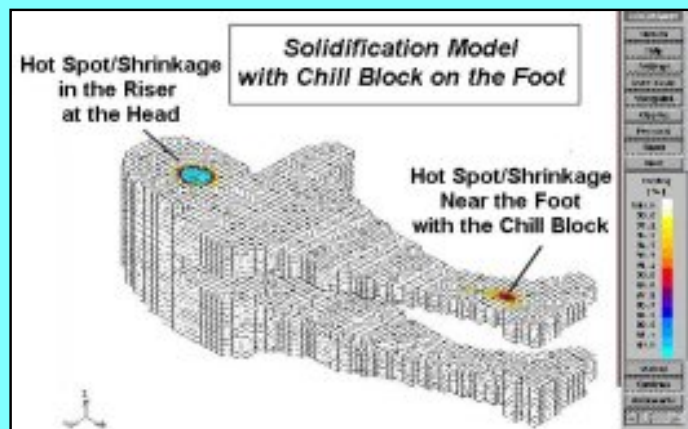

Solidification Model

## Approach A -- Chill Block on the Foot

- In Approach A, a chill block is placed on the foot of the plate to prevent a hot spot.
- But computer solidification modeling showed that the chill block “pushes” the hot spot into the arm of the plate where shrinkage will occur.

The chill block is not a good method to eliminate shrinkage.  
[Go back and choose another approach.](#)

[Back](#)

26



[Return to SFSA](#)  
[Home](#)  
[Page](#)

Copyright 2003 by the Steel Founders' Society of America. All rights reserved.  
 Address comments to: [blairr@sfsa.org](mailto:blairr@sfsa.org)  
 Last Modified: April, 2003 by STG



[Page 1](#)

In cooperation with  
[Pacific Steel Castings](#)



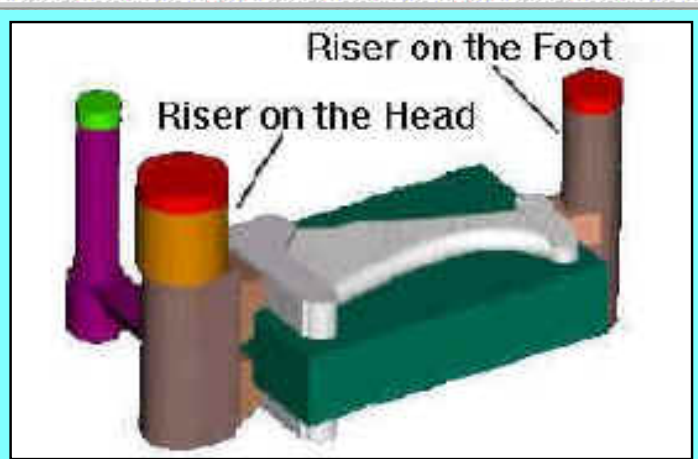

## A Design Study in Steel Castings - Steel Plates in BOP Valve



Riser on the Foot

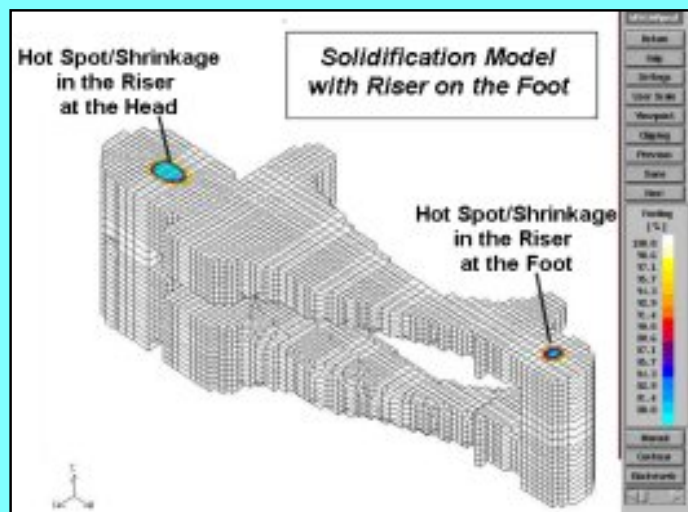

Solidification Model

## Approach B -- Riser on the Foot

- In Approach B, a riser is placed at the foot of the plate to feed metal into that hot section.
- Computer solidification modeling shows that the riser “pulls” the hot spot out of the foot of the plate into the riser, producing a sound casting.

**The riser at the foot is a good method to eliminate shrinkage.**

**[Go on to the next design issue.](#)**



[Back](#) [Next](#)

27



[Return to SFSA Home Page](#)

Copyright 2003 by the Steel Founders' Society of America. All rights reserved.  
 Address comments to: [blairr@sfsa.org](mailto:blairr@sfsa.org)  
 Last Modified: April, 2003 by STG



[Page 1](#)

In cooperation with  
[Pacific Steel Castings](#)





A Design Study in Steel Castings - Steel Plates in BOP Valve

## Quality Assurance

*The Pacific Steel foundry applies well-defined techniques at each stage of the casting process to assure quality.*

- Precise casting process control of the alloy chemistry, mold fabrication, melt temperature, and pouring method.
- A comprehensive inspection plan in production:
  - Checking critical dimensions and surface finish/appearance.
  - Brinell Hardness on sample castings.
  - Magnetic particle evaluation (ASTM E709).
  - Ultrasonic testing.



Hardness Tester



[Back](#) [Next](#)

28



[Return to SFSA Home Page](#)

Copyright 2003 by the Steel Founders' Society of America. All rights reserved.  
 Address comments to: [blairr@sfsa.org](mailto:blairr@sfsa.org)  
 Last Modified: April, 2003 by STG



[Page 1](#)

In cooperation with  
[Pacific Steel Castings](#)





A Design Study in Steel Castings - Steel Plates in BOP Valve

# Lessons Learned

**Pacific Steel Casting engineers worked in close collaboration with the OEM system engineers to develop a component design which met the performance and quality standards and could be cast in a cost-effective process.**

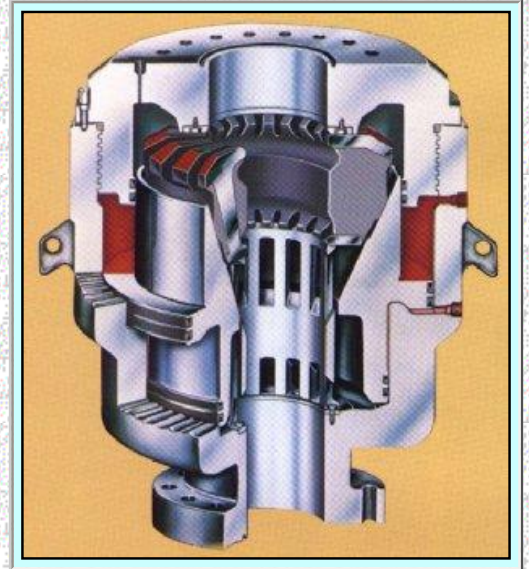

*Key "Lessons Learned" were --*

1. **Selection of the right alloy is key to achieving the required strength and hardness.**
2. **Solidification modeling is a powerful tool for quickly producing a flaw-free casting with the minimum number of mold design iterations.**



[Back](#) [Next](#)

29



[Return to SFSA Home Page](#)

Copyright 2003 by the Steel Founders' Society of America All rights reserved.  
Address comments to: [blairr@sfsa.org](mailto:blairr@sfsa.org)  
Last Modified: April, 2003 by STG



[Page 1](#)

In cooperation with  
[Pacific Steel Castings](#)





A Design Study in Steel Castings - Steel Plates in BOP Valve

## Summary

# Steel Insert Plates for Blowout Preventer Valves

- Solidification modeling was a critical factor in quickly developing a cost-effective casting approach and mold design for the steel insert plates.



For further information on precision casting of steel alloys, contact --  
 Ravi Anaparti at Pacific Steel Castings Phone-- 510-525-9200  
 E-mail -- [ranaparti@pacificsteel.com](mailto:ranaparti@pacificsteel.com), Web Site = <http://www.pacificsteel.com>

### Acknowledgment --

*The metalcasting design studies are a joint effort of the Steel Founders' Society of America and the American Foundry Society. Project funding was provided by the American Metalcasting Consortium Project, which is sponsored by the Defense Logistics Agency, Attn: DLSC-T, Ft. Belvoir, VA, 22060-6221*



[Back](#) End



[Return to SFSA Home Page](#)

Copyright 2003 by the Steel Founders' Society of America All rights reserved.  
 Address comments to: [blairr@sfsa.org](mailto:blairr@sfsa.org)  
 Last Modified: April, 2003 by STG



[Page 1](#)

In cooperation with [Pacific Steel Castings](#)



## Feature B - Interior Edge of the Bar

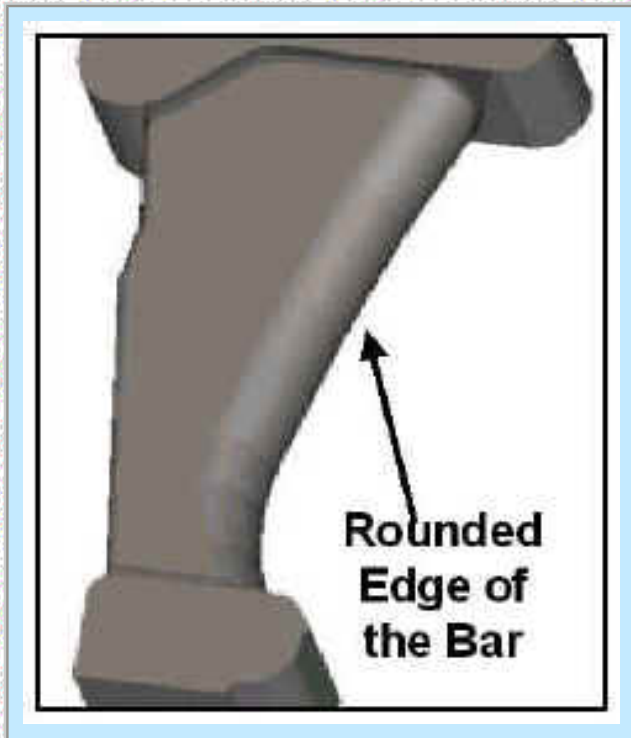

- A generous radius on the edges of the bar will eliminate two sharp corners, reduce stress and produce better fill in this section that is tensile stressed.

*The interior edges of the bar should be radiused.*

*Go to the [Next Design Issue](#) or  
[Go Back for Another Choice!](#)*



[Back](#) [Next](#)

13



[Return  
to SFSA  
Home  
Page](#)

Copyright 2003 by the Steel Founders' Society of America All rights reserved.  
Address comments to: [blairr@sfsa.org](mailto:blairr@sfsa.org)  
Last Modified: April, 2003 by STG



[Page 1](#)

In cooperation with  
[Pacific Steel  
Castings](#)



## Feature C - Base of the Foot



- The base of the foot is not highly stressed and will fill without problem.
- Radiusing is not necessary

*The base of the foot does not need a radius.  
Go to the [Next Design Issue](#) or  
[Go Back for Another Choice!](#)*

