

# ENVIRONMENTAL NEWS

## **SLUDGE TREATMENT PLANT**

ANDRITZ delivered a turn-key plant for sewage sludge to Anglian Water, UK (*Page 26*)

## **AFTERMARKET**

23 specialised service and maintenance locations worldwide to guarantee optimal service to our customers (*Page 10*)

## **FOX RIVER**

Successful project in USA: cost-efficient regeneration of polluted waters (*Page 16*)

# CONTENTS

**03**  
All-round competence  
in sludge treatment

**04**  
Optimum  
sludge utilization

**10**  
ANDRITZ continues growth  
in the after-sales business

**12**  
Centrifuge maintenance in  
municipal wastewater treatment

**16**  
Successful project at Fox  
River, USA: cost-efficient  
regeneration of polluted waters

**17**  
Comprehensive product  
portfolio for sludge thickening

**18**  
Decanter solutions  
for biogas production

**18**  
Flexible in  
biofuel production

**20**  
CentriCo: new control  
system for centrifuges

**21**  
Desalination  
sludge treatment

**21**  
ANDRITZ sludge thickeners  
for Paris WWTP

**22**  
Sludge treatment  
under palm trees

**23**  
New high-performance  
centrifuge confirms expectations



**24**  
New scraping device  
extends filter cloth lifetime

**26**  
Turnkey sludge  
drying plant for Tilbury

**28**  
Valuable biological waste:  
belt dryer for fermentation residues

**29**  
With EcoDry to a sewage treatment  
plant that is energy self-sufficient

**30**  
Energy recovery from waste gas  
in cement production

**32**  
Sewage sludge drying: economical  
and environmentally friendly

**35**  
Fully encased  
belt drying plant for Nufri

**36**  
ANDRITZ supplies the world's largest  
belt dryers with 8 m belt width

**38**  
Safety in  
drying plants



# All-round competence in sludge treatment

A broad product portfolio, comprehensive know-how, over 40 years of experience, hundreds of references, and a worldwide network of specialist service centres make ANDRITZ ENVIRONMENT & PROCESS one of the world's leading suppliers of sludge treatment systems.

ANDRITZ has by far the most extensive product portfolio for customer-specific solutions in solid-liquid separation, extending from screens for waste water treatment, to centrifuges, belt presses and filter presses for dewatering, to drying and incineration plants for thermal sludge treatment. In addition to our intensive research and development work, acquisition of companies with leading technology also plays an important role: Well-known companies, such as Guinard, Bird and Humbold, Rittershaus & Blecher, Netzsch, or Fließbett Systeme Ravensburg have been taken over by and integrated very successfully into the ANDRITZ GROUP. And ANDRITZ is continuing with this strategy. In the past few months, ANDRITZ has further strengthened its product range for solid-liquid separation by acquiring the German centrifuge specialist KMPT, the Italian separator manufacturer Frautech, and the South African dewatering specialist for mining applications, Delkor Capital Equipment.

## System solutions form a single source

With our extensive product portfolio we can meet our customers' growing demand for system solutions very well, both in the mechanical and thermal sludge treatment sectors. With the complete product package offered by ANDRITZ, our customers are no longer confronted with interface problems. Customers also have the assurance that the requirements of the applicable EU directives on explosion protection (ATEX) and air pollution are safely met – a fundamental requirement, particularly in thermal sludge treatment.

## Service in the forefront

ANDRITZ focuses on more than just single delivery of a machine or plant: Our prime objective is to enable the customer to draw



the maximum benefit from his investment over the entire lifetime of the equipment. Our support work begins by defining the optimum equipment items for the respective application and extends from integration into the customer's process, production and installation of the plants, to lifelong customer support. With our automation technology – the ANDRITZ GROUP has a global team of automation specialists – we can integrate our systems into the customer's process to optimum advantage and ensure that the equipment is controlled to meet the given requirements and can thus be operated with maximum efficiency. We ensure a long service life with a high performance level by providing machine updates, original spare part supplies, as well as prompt and competent on-site service through our network of 15 dedicated service centres and 8 repair shops worldwide. When extending our service capacities, we focused both on setting up our own locations – in 2009 we again opened a repair centre for centrifuges in Whitbank, South Africa – as well as on acquiring established service companies (such as Contec Decanter Inc. in the USA and Decanter Pty Ltd. in Australia). In addition, we cooperate locally with a large number of certified partner workshops.

## Strong business area – strong ANDRITZ GROUP

The ANDRITZ GROUP, with some 13,000 employees and headquartered in Graz, Austria, is a leading international supplier of plant, systems and services to various branches of industry. The company looks back on a history of over 150 years and has spread to around 150 sites all around the world. It numbers among the world market leaders in each of its five business areas (HYDRO, PULP & PAPER, METALS, ENVIRONMENT & PROCESS, FEED & BIOFUEL).

The ENVIRONMENT & PROCESS business area has held its ground through the economic crisis. In 2009, the business area recorded sales in the region of 320 million Euros. Spare parts, customer service work and maintenance play an important role here, contributing approximately a quarter of the sales volume. So far, ANDRITZ has supplied a total of over 4,000 centrifuges and 7,500 filter presses for sludge dewatering. In thermal sludge drying, ANDRITZ has delivered 137 plants with a total of 181 drying lines, which together dry approximately 9 million tonnes of sludge a year.

# Optimum sludge utilization

Systems tested worldwide, from dewatering to thermal utilization: from hazardous waste materials to dry granulate and minimum residue.

Developments on the sludge treatment market are determined by strict environmental regulations. According to the requirements of Germany's Waste Storage Ordinance, it has been prohibited to dispose of untreated sewage sludge in landfills since June 1, 2005. But spreading sewage sludge on agricultural land and thermal utilization also harbours risks for man and the environment according to public opinion, although sewage sludge as the final product of each wastewater treatment process bears great potential for utilization of the material and energy it contains. The concerns expressed by public opinion on dangerous substances contained in the sludge and on the environmental risks have led to a rising demand for safe overall treatment concepts that offer advanced solutions on how to re-use sludge and recover energy.

With more than 25 years of experience and the wide spectrum of technologies available, ANDRITZ's strength lies in the ability to provide custom-tailored solutions for efficient sludge treatment, from thickening to dewatering and drying, and on to thermal utilization, including the process control and instrumentation required to operate the plant. Since there are several systems to choose from for each process stage, the different framework conditions of each respective project can be addressed to the optimum.

Mechanical dewatering with filter presses and centrifuges forms the basis of sludge drying in which the sewage sludge is converted into a low-odour, free-flowing product that can be stored and transported easily, in short, a product that is suited to any and all reuses. ANDRITZ offers belt, drum, and fluidized bed dryers. Ecody is the optimum unit to complement sludge drying technology - a process where dewatered



▲ Power Press Type S for treatment of municipal and industrial sludges

sludge can be dried without requiring primary energy and where the dried sludge is used as fuel in the cyclone furnace (used to generate the heat needed for drying). Ecody uses the calorific value of the sludge for its disposal and does not require any other energy source.

### Selecting the dewatering system

Selection of the equipment type for a cer-

tain application must be closely tuned to the needs of the user. Technologically, the different unit types can be classified according to the method of applying force (belt presses, centrifuges, and chamber filter presses). The following table compares the different systems (application: digested sludge, approx. 40 m<sup>3</sup>/h; 3% ingoing dryness, 1,200 kg DS/h, OTS approx. 67%, 8,000 operating hours/year):

### System comparison of sludge dewatering units

Mechanical dewatering	Belt press	Centrifuge	Chamber filter press
Capital investment	100%	120%	180%
Useful life	10 years	20 years	30 years
Operating mode	continuous	continuous	batch
Polymer consumption	100%	120%	95%
Power consumption (in kW/m <sup>3</sup> )	0.10	0.5	0.3
Solids discharge	21–25%	24–28%	26–30%
Sludge cake amount per year	100%	88%	82%



▲ These six D7LL decanters were supplied to Sungai Semenyih, Kuala Lumpur, Malaysia, one of the largest drinking water treatment plants in Southeast Asia. Sungai Semenyih use the decanters to treat the drinking water sludge as a result of the rising ecological awareness of the Malaysian government.

The belt press has advantageously low investment costs if the volume of sludge is low. The throughput per unit is lower than for the other two dewatering unit types, so it may be necessary to buy 2 lines, therefore reducing the capital cost advantage. Dewatering is very careful, and the flocculent and energy requirement is low. The drawbacks of the belt press are its low final dryness and its open system. Belt presses are mostly used when the sludge volume is low, in countries with shortfalls in supply of electricity or chemicals, and in countries with a lack of infrastructure in the maintenance of fast rotating machines.

As the costs for sludge disposal have risen considerably over the past years, centrifuges have become the most widely used dewatering units. The lower sludge cake weights more than offset the somewhat higher energy and polymer consumption. In addition, centrifuges work in a completely closed, continuous environment.

The filter press has the highest capital expenditure for the fully automatic model. For very low sludge quantities it is still also available in the manual design mode and offers a favourable cost/benefit ratio there. The main application areas lie in tasks involv-

ing difficult sludges, for instance in drinking water treatment and in industry. The large dewatering surface – often several square meters - and the high pressure secure optimum dryness. As an additional feature, it is possible to wash out chemical residues from industrial sludges.

By installing an additional scraping device, sticky cakes can also be removed safely in

a fully automatic process. Further benefit that the filter press offers are low energy and polymer consumption, with open design and batch processing methods as its advantages.

#### The right thermal process for each sludge quality

Mechanical dewatering is followed by thermal dewatering in the drying stage, pro-



▲ ANDRITZ membrane filter press used to dewater sludge from municipal wastewater treatment plants. The press reduces the sludge volume and produces clear filtrate that can be discharged to the sewer.

ducing sewage sludge granulate with a dry solids content in excess of 90%. In addition to a substantial reduction in the volume of sewage sludge to be disposed of, drying - particularly if it uses waste heat - is an important step along the route from waste (sewage sludge) to a product whose content substances and energy can be put to good use (dry granulate).

With the belt, drum and fluidized bed dryer, ANDRITZ has three drying systems at its disposal that allow it to adapt its solutions flexibly to the requirements on site. Here, the thermal energy to be provided for drying plays a key role because this is the factor that largely determines the cost-efficiency of sewage sludge drying. Whereas belt and drum dryers use convective processes in which the heat required to evaporate the water is applied to the product with the drying gas, in the fluidized bed dryer heat is mainly transferred in an indirect process by

means of a heat exchanger integrated into the dryer. If there is a source of primary energy available (natural gas, biogas, oil, and so on), drum and fluidized bed dryers provide the most compact units. The drum dryer requires hot gas temperatures of  $>400^{\circ}\text{C}$ , which are generated when gas or oil is burned. In addition to primary energy, which is used as a heat carrier to heat thermal oil or steam, the fluidized bed dryer can also use waste heat in the medium temperature range (flue gases  $>150^{\circ}\text{C}$ , heating steam  $>5$  bar) and still be operated economically. The belt dryer has distinct advantages in the use of waste heat at low temperature levels (flue gases  $<150^{\circ}\text{C}$ , heating steam  $<5$  bar, hot water  $>90^{\circ}\text{C}$ , and so on). Experience has shown that these heat sources can be utilized at low cost.

#### Operating requirements

Wastewater treatment is a chemical-biological process that is subject to fluctuation

(affected by the seasons and also due to the effluent discharger). Ultimately, these fluctuations are also reflected in the properties of the sewage sludges that are produced. All three plant concepts are capable of handling any fluctuations in the sludge quality (DS, organic content, and so on). This is particularly important if the drying plant handles sewage sludges from different waste water treatment plants.

Based on many years of operating experience with more than 150 drying plants for sewage sludges with a wide range of different properties and water evaporation rates ranging from 0.5–12 t/h per drying line, ANDRITZ has developed drying systems that stand out due to their great flexibility. With these systems the sewage sludges are treated safely, economically and reliably, and the basic requirements for meeting the stringent demands for safe disposal of the sewage sludges are fulfilled.

Whereas the dewatered sludge is mixed with a certain proportion of dry granulate in belt and drum dryers, in fluidized bed dryers the sewage sludge is pumped and ground in a special feed system and then mixed into the fluidized bed. In particular, belt and fluidized bed dryers can be operated without an operator being present at all times.



◀ Belt drying plant for sewage sludge in Antalya, Turkey



▲ Drum drying plant consisting of one line DDS 70 for drying of municipal sludge

### Granulate quality

The final product of sewage sludge drying from all three systems is a hygienized granulate with ...

- a dry solids content in excess of >90%,
- low dust content, and
- stable biological properties.

The dry product obtained in this way can be transported and stored safely and easily thanks to the quality of the granules and its biological stability. This granulate is suitable for uses requiring its substance content or its thermal energy, where the carbon-neutral properties are greatly appreciated in thermal utilization.

### Sewage sludge utilization methods

The dried sludge granulate can be used in different ways extending far beyond the traditional uses (composting, agriculture, incineration). The main field of application,

however, is still as fertilizer in agriculture. The biologically stable granulate (free of germs to a large extent), which is enriched with nutrients, can be used easily and at no risk.

The use of sludge as an alternative fuel is becoming an increasingly interesting proposition. As an alternative, thermally dried sludge can be used in refuse-fuelled power stations, coal-fired power stations, and cement works. The cement industry plays an important role in utilization of sewage sludge. While agricultural use only utilizes the content substances, burning the sewage sludge together with other materials in refuse-fuelled or coal-fired power stations make exclusive use of the thermal energy. If, however the sewage sludge is used in a cement works, both the substance and the energy content are fully utilized in compliance with the basic principles of life-cycle management. The primary energy saving

that comes from using sewage sludge as fuel also reduces the overall CO<sub>2</sub> emission pursuant to the Kyoto Protocol.

### Safety engineering

Sewage sludge is an organic product and thus dictates the safety measures required in the drying system. Whatever the drying system, the release of dust from the sewage sludge cannot be excluded during dry material handling. If the dust/oxygen concentration reaches a certain level and a minimum ignition energy is present, explosions are possible.

In order to avoid explosions and fire, both fluidized bed drying and drum drying are conducted in an inert gas atmosphere – i.e. with a much lower oxygen content (primary safety measure). This inert gas atmosphere is used in fluidized bed drying for the entire drying process, as well as in transport and storage of the dried material. In drum dry-

ing, structural fire and explosion protection measures are used, such as spark detection with automatic extinguishing system, explosion suppression, and explosion pressure venting (secondary measures).

Due to the lower temperature level and high dust dilution in the drying air, belt drying does not require inertisation, but it is equipped with fire extinguishing systems and water jets that are triggered by CO and temperature sensors. All three drying systems are subject to the safety engineering requirements according to the safety analysis pursuant to EN 1050; conformity with 98/37 EC and 94/9 EC (CE + ATEX).

#### Emissions caused by the drying process

As a result of the drying process, slightly volatile components bound by adsorption or enclosed in capillaries are forced out with the drying air. In many cases, the exhaust air limit values required by the authorities cannot be met without an additional exhaust air cleaning process. The official operating permit is often subject to the requirements of the German directive "TA-Luft". The following emission sources of a drying plant should be taken into account:

1. sludge treatment (delivery, storage and transport),
2. aspiration of the sludge silo to prevent explosive mixtures of methane and air, and
3. emissions from the dryer itself.

While the emissions mentioned in 1. and 2. are not related to the drying system, the concentration and the volume of exhaust air from drying differ according to the process used. The exhaust air cleaning process uses chemical scrubbers and also biofilters if needed, depending on the sludge type and concentration of contaminants. A thermal post-combustion stage is often used in drum drying plants, particularly for dryer exhaust air with a strong unpleasant odour (e.g. from drying of raw and undigested sludges). The exhaust air volume for drying is very low in fluidized bed drying (<math><200\text{m}^3/\text{h}</math>), but the air is highly contami-



▲ Fluid bed dryer for sewage sludge in Leuven, Belgium.

nated. The processes involved in belt and drum drying result in ten times the exhaust air volume, thus increasing the overall cost of air cleaning. In addition to the gaseous emissions, the drying plant also produces wastewater, which is essentially evaporated water that has been removed from the sewage sludge and eliminated from the gas stream in a condensate stage. The contaminated wastewater must be also be treated and cleaned in a suitable way. In addition,

the heat generated during evaporation of the water in the dryer must be dissipated. While the heat from operating a sewage treatment plant can be transferred into the feed from the plant, sites in industrial zones generally need a cooling tower for heat dissipation. The waste heat from the drum and fluidized bed dryer, with a temperature of approx. 60°C, can be used to heat the digester tower, for example.



### Comparison of ANDRITZ Sludge Drying Systems at a glance

ANDRITZ Dryer System	DDS Drum Drying System	BDS Belt Drying System	FDS Fluidized-Bed Drying System
Principle	convective	convective	contact/convective
Drying temperature on granulate surface	85°C	75°C	85°C
Sludge infeed	Via sludge pump, sludge mixed with recirculated material in mixer for granulate formation (back mixing)	Sludge mixed with recirculated material in mixer for granulate formation (back mixing)	Direct sludge input via sludge pump and infeed device to fluidized bed
Treatment of variable sludge grades	High flexibility due to back-mix control	High flexibility due to patented back-mix control; sludge particles are under no mechanical stress during drying. Relatively insensitive to coarse parts, plastics and hairs.	High flexibility with sludges that can be pumped, with varying dry substance and organic content, limited ability for high fibre contents.
Heating medium	Flue gas 400 - 600 °C	Hot air or flue gases >150°C Thermal oil >150°C Hot water >90°C Steam >150°C	Flue gases >180°C Thermal oil >150°C Steam >5 bar
Energy sources	Off-heat from cogeneration flue gas if temperature > 400°C Natural gas, biogas, LPG.	- Off-heat from cogeneration - Hot water - Natural gas, fuel oil, biogas in conjunction with thermal oil/steam as heat carrier - Process steam.	- Off-heat from cogeneration - Natural gas, fuel oil, biogas in conjunction with thermo oil/steam as heat carrier, - Process steam.
Dryer operation (referring to direct/indirect contact of heating medium with sewage sludge)	direct	direct	indirect
Operational requirements	Water evaporation rate: 3.0 -12 t/h  - Automatic plant operation - Automatic control of varying sludge characteristics - Compact design, several storeys.	Water evaporation rate: 0.5 – 10 t/h  - Automatic plant operation, no operator attendance during the night - Automatic control of varying sludge characteristics - Installation on one level is possible.	Water evaporation rate: 1.5 - 12 t/h  - Automatic plant operation, no operator attendance during the night - Automatic control of varying sludge characteristics - Compact design, low space requirement, several storeys.
Product quality	- Granulate 1-4 mm - Globular, highly pressure resistant, narrow grain range and high density - Minimum dust - > 90% DS - Class A product due to long dwell time in the dryer	- Granulate 1-8 mm - Less uniform shape and size - slightly higher fines content than with DDS - >90% DS - Class A product due to extended drying zone.	- Granulate 1-4 mm - Coarse surface - Minimum dust content - > 90 % DS - Class A product due to long dwell time in dryer.
Safety engineering (Explosion, fire and personal protection)	- Inertisation of the drying circuit ensured by flue gases and evaporated water; - Constructive explosion protection for peripheral plant components - Product cooling	- Dust monitoring - Sprinkler plant actuated when CO limit values are reached - Constructive explosion protection for peripheral plant components - Product cooling	Inert gas operation from the dryer up to and including the product silo at each operating status. Product cooling
Emissions: - gas - water - dust	- Waste air treatment with wet scrubber combined with biofilter or re-burning - Waste air quantity < 10,000 m³/h - Wastewater (condensate + make-up water) - Underpressure if process is closed Aspiration for product-carrying units	- Waste air treatment with wet scrubber and/or biofilter - Large volumes of waste air > 10,000 m³/h - Wastewater (condensate +make-up water ) - Underpressure if process is closed - Aspiration for product-carrying units	- Waste air treatment with scrubber plus biofilter- very low waste air quantities < 200 m³/h - Waste water (condensate + make-up water) - Dust and gastight construction of all units with product



■ Repaircenter  
■ Servicecenter

## ANDRITZ continues growth in the **after-sales business**

Supplying high-quality products is part of the ANDRITZ corporate strategy. ANDRITZ strives to support customers in extending the efficiency and value of their solid/liquid separation equipment by offering maintenance and repair options over the entire plant lifetime. For drying plants, ANDRITZ offers service and maintenance as well as performance appraisals and upgrades to improve operation conditions and, thus, achieve maximum efficiency for customer plants.

There are over 30,000 ANDRITZ dewatering units and 120 drying plants in operation worldwide. ANDRITZ is aware that service business is local business. Take centrifuge service as an example: Transporting a centrifuge to a repair and service center is profitable only up to 1500 km. ANDRITZ is continually developing and upgrading the capacities of its service and repair capabilities, thus strengthening its worldwide base of centrifuge service companies. ANDRITZ customers can use a total of 15 repair shops for centrifuges all over the world. Service for drying installations is performed from our local ANDRITZ locations in cooperation with our technology centers located in Austria, Germany and the USA.

### Why should service work be carried out by specialists?

In today's world of decreasing operational and maintenance budgets, plant availability is a factor of growing importance. ANDRITZ service specialists understand this demand and ensure that downtime is kept to a minimum. Operators of thermal drying plants, in particular, are faced with increasingly stringent requirements from local authorities on safe operation and safety equipment. Safety upgrades to existing installations require a thorough investigation of all plant aspects by process specialists to take the individual plant design into account. ANDRITZ has the lead in the market on dryer safety and sets the market standards for a safe plant de-

sign. Thus, ANDRITZ is the best partner for any safety improvement to be performed.

### Advantages:

- Sustained process capabilities
- Very high availability and minimum downtime
- Continuous product quality
- Lasting plant value
- Competent process specialists to upgrade plant performance
- Safety enhancements on drying plants carried out by experts

### Implementation of SAP

ANDRITZ is in the process of implementing a global SAP system that will enable even faster delivery of critically needed parts and further minimize equipment downtime through global visibility of parts inventories. SAP has been implemented for the ANDRITZ facilities in the US, France, Germany, and China.

### ANDRITZ capabilities for service orders

We offer a number of advantages related to services agreements:

- Fixed and therefore calculable maintenance cost
- Regular inspections and process optimizations
- Preventive maintenance
- Planned storage of spare parts
- Diagnostic services via modem or with special measuring instruments (e.g. endoscopy)
- Operator training for maintenance and operation
- Temporary assistance with personnel provision or mobile dewatering plants
- Modernizations
- 24h/7 days per week call-out



## Special service packages

### Filter presses:

- Revamping of cloth washing plants
- Optimization of plates and filter cloths
- Economical repairs even after decades of operation
- Modernization of controls
- Optimization of sludge conditioning
- Recess to membrane plate conversion

### Centrifuges:

- Improvement of wear protection
- Modernization of controls
- Reconstruction to backdrive
- Performance increase with patented XL-Plus technologies
- Rotors for rent to help bridge repair times
- Screw replacement programs

### Dryers:

- Service contracts for regular maintenance and plant investigations
- Consultancy services for optimizing the plant operation
- Plant upgrade to improve performance and safety
- Performance appraisals of drying plant operations
- Audits of dryer plant operation and safety

# Centrifuge maintenance in municipal wastewater treatment

Operators now enjoy greater freedom and can reduce costs thanks to the individual maintenance intervals allowed under the new legal framework for maintenance and safety.

Municipal wastewater treatment plants mainly use horizontal centrifuges, chamber filter presses, or belt filters to separate the sewage sludge from the liquid. At the moment, a distinct decline in filtration with chamber filter presses can be observed on the wastewater market in Germany. The main reasons for this are the high investment costs, the open design, and the batch-type operation of this equipment. The situation for sludges from drinking water treatment, which are difficult to dewater, is quite different, where fully automatic filter presses fitted with a scraping device are preferred. As a result of their low initial cost and low polymer consumption for smaller plants, belt presses are gaining importance once again on the German market.

## Centrifuge for sludge dewatering

As a continuously operating unit, the centrifuge can handle large specific throughputs of 5 to 300 m<sup>3</sup>/h when thickening and dewatering different sewage sludges and in various stages of wastewater cleaning. Separation operates on the principle of sedimentation, i.e. using the difference in density between solid and liquid, where the separation forces in operation are significantly higher as a result of high centrifugal acceleration (up to 5,200 g-force) compared with sedimentation under the force of gravity alone.

In a centrifuge, the sewage sludge is brought into the rotating bowl through a centrally located feed pipe. The flocculating agent is also added at the inlet in order to enhance the clarifying effect. Inside the bowl, the rotating movement causes a cylindrical ring of liquid to form, and this is where the solids separate. The sedimented solids are conveyed to the conical end of the bowl by a scroll moving at a different speed

(differential speed) to the rotating bowl, ultimately to be lifted out of the liquid in the bowl and discharged through openings in the centrifuge as mechanically dewatered solids with low residual moisture content. The liquid (centrate) on the other hand flows over a liquid weir located at the other end of the bowl and which determines the liquid level in the bowl.

Specially developed open flights have proved effective for the sludge application because the liquid can thus flow in axial direction to the outlet holes, which improves the quality of the centrate because the flow speeds are much lower than in a spiralling flow current along a closed flight.

By including a disc at the beginning of the conical part, a high pond depth (negative pond) can be used without liquid escaping on the solids side. A higher liquid pond

increases the dewatering pressure and has a positive effect on the final dryness obtainable.

With the exception of a few special cases, solid bowl centrifuges (also referred to as decanter centrifuges) are mounted horizontally. The rotors are usually fitted with top-quality anti-friction bearings either with a continuous supply of oil from a recirculating oil lubrication system or lubricated intermittently with grease. The rotor is driven by an electric motor with a V-belt or, on rare occasions, by a hydraulic system. There are two different back-drive concepts – the electric and the hydraulic system – to obtain the differential speed. Both systems involve different maintenance and service measures.

## The electric back-drive

All gear units used are epicyclic gears, the most well-known of which is certainly the

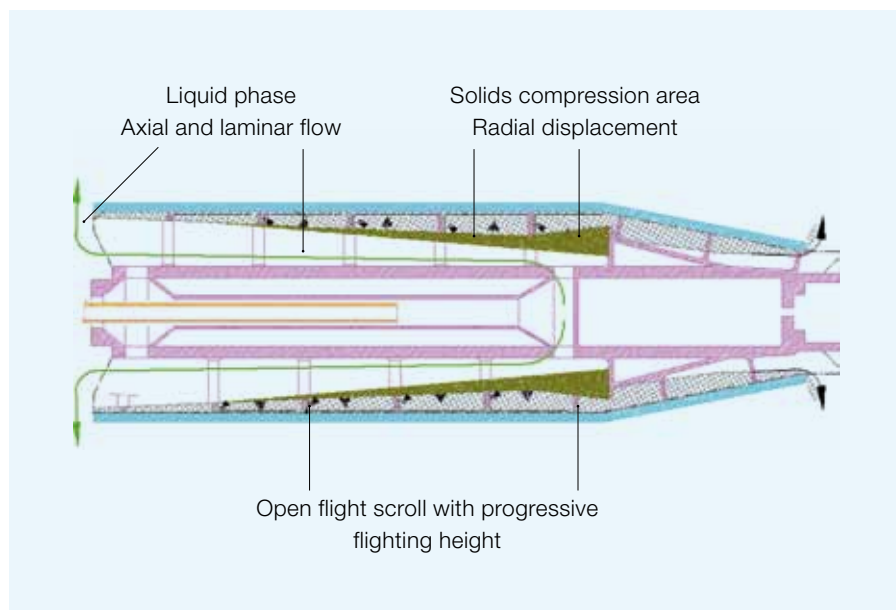

▲ Sectional view of the main elements of a solid bowl centrifuge in counter-current design

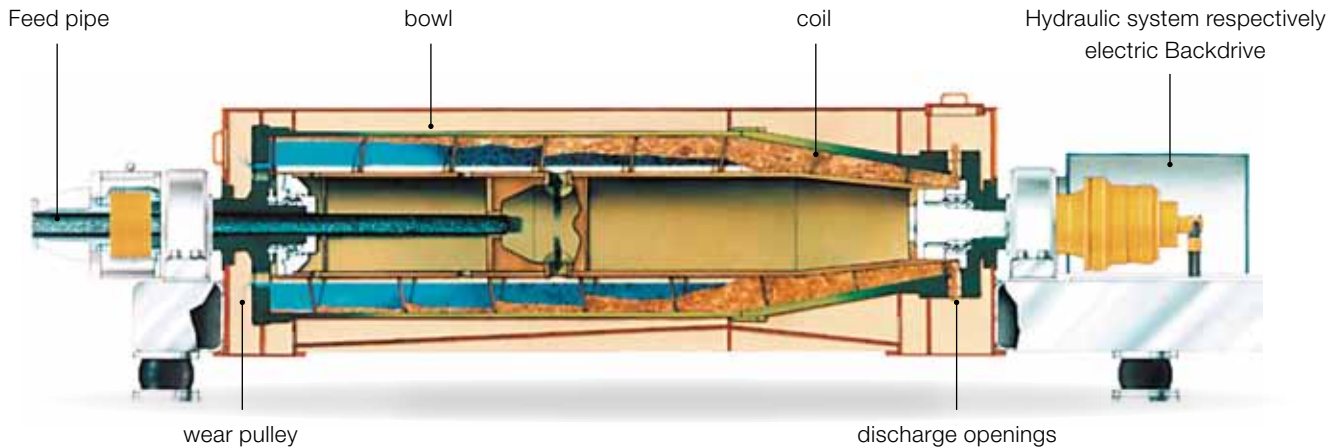

▲ Sludge centrifuge and conventional centrifuge

planetary gear. The back-drive turns the ring gear, which is firmly attached to the rotor. In systems that are not adjustable, the sun wheel is fixed and the planet wheels roll along between the ring gear and the sun wheel. The axes of the planet wheels make a circular movement whose speed is determined by the transmission ratio of the gear unit. In adjustable systems, the speed of the sun wheel can be varied with the aid of a frequency-controlled electric motor and thus, the differential speed between the bowl and the scroll can be changed. The gear is controlled by measuring the current draw, which is used to calculate the required torque of the back-drive motor.

#### The hydraulic back-drive

The hydrostatic scroll drive consists of the hydromotor (Rotodiff) mounted on the centrifuge, the pump unit, and the controlling and regulating unit. The hydromotor is attached directly to the bowl and connected to the scroll via the stub shaft. The hydrostatic submergible pump in the pump unit generates an oil flow rate that drives the hydromotor and thus also the scroll. The control block of the pump unit controls the flow rate and thus regulates the differential speed between the bowl and the scroll.

#### Centrifuge maintenance

The operating principle of the centrifuge as a fast-moving machine requires some spe-

cial aspects of maintenance to be taken into consideration in order to guarantee proper function and satisfy the safety aspects. Machinery Directive 89/232/EEC and the relevant succeeding directives, as well as DIN standard EN 12547, "Centrifuges, common safety requirements" published in the Official Gazette of the European Communities in 1999 as a harmonised standard, apply to new machines. The German accident prevention regulations (UVV - VBG 7 z) for centrifuges can no longer be taken as the basis for compliance with the Machinery Directive. Nevertheless, local accident insurance associations and insurance companies do fall back on the inspection and maintenance logs for older machines, as well as in the event of accidents and more substantial damage. Where it was previously required to conduct an annual inspection of the centrifuge in operation and an inspection of the machine when opened every three years, the limit values for unbalance or vibrations, and thus the inspection and part replacement intervals for safety-relevant components, are now defined individually for each centrifuge on the basis of the permitted speed range and the maximum filling level, depending on the corrosion and wear status.

The maintenance log states the maintenance work performed (time and type of work), as well as the inspection intervals,

scope and methods. Maintenance can be performed by specially trained staff of the operating company and includes changing of consumables, as well as adjusting and repair work.

#### Inspection in operating status

This inspection consists of a visual check on the machine/rotor when installed in the centrifuge. When the machine has been switched off and disconnected from the power supply, the cover is opened and the machine elements inspected visually. This inspection also includes a visual check on the bolted connections for corrosion and wear, which may limit subsequent removal of the bolts if the machine is to be disassembled. The outlet holes are inspected visually for signs of wear.

An endoscopic wear analysis is conducted with digital video equipment with the centrifuge fully assembled, but not in operation. A probe with a diameter of 8.4 mm is inserted through the feed pipe into the feed chamber and on into the centrifuge bowl. The metal arc lamp used here, with a luminous flux of 2,600 lm, generates sufficient lighting to pinpoint wear and the beginnings of any damage. If there is an inspection port available, wear on the flight can also be measured with a depth gauge.

Mounting and correct setting of the weir

discs are also inspected. At the drive, the condition of the motors and the V-belt tension are checked. When the machine is running, a noise check, leak test, vibration measurement, and bearing temperature check are carried out. Depending on the type of system for setting the differential speed between the bowl and the scroll, the appropriate inspections are performed on the gear unit. If the centrifuge has a hydraulic gear unit, the overflow and control valves must be inspected, the hydraulic lines checked, and the oil sampled and analysed; for gear units with electronic controls, the oil must also be sampled and analysed, and the V-belt and gear unit inspected. Finally, a function test is run on the control equipment and electrical interlocking.

#### Inspection with the centrifuge open or at the manufacturing works

Depending on the size of the machine and the equipment available on site, machines with a diameter in excess of 500mm are not normally inspected in the plant, but in a repair shop or – even better – at the manufacturer's works because only the manufacturer has the appropriate drawings showing the tolerances and the appropriate templates.

After being cleaned, the scroll is pulled out of the bowl with a suitable device and measured using a template. All of the relevant fits at the bearing seats and fitting rings are checked, compared with the original drawings, and adjusted if necessary. The wear on the flights is repaired by retouching. In order to achieve acceptable service life, sintered tungsten carbide segments are mounted on a stainless steel or carbide base and then welded on to the flank of the flight if abrasive sludges are involved. After machining, the scroll and the bowl are both dynamically balanced and the machine fully assembled again. Then a test run is performed for a limited time in the test bed.

#### Maintenance contracts

Here are the details on a maintenance contract, taking the maintenance and inspection work for centrifuges operated by the Berlin Water Authority (BWB) as an ex-

ample. The Berlin Water Authority operates six sewage treatment works that receive around 620,000 m<sup>3</sup> of wastewater. The plants are fitted with biological treatment stages, including elimination of phosphorus and nitrogen. The sludge produced is dewatered, then either incinerated or dried at the plants in Wassmannsdorf, Ruhleben, Schönerlinde and Münchehofe. Based on the reference period from 2003 to 2005, BWB was anxious to increase the availability of the plants and guarantee the running time of the centrifuges for 2006 to 2009 by improving maintenance and repair services – at least at no additional cost. Maintenance and repair services were improved by means of an all-inclusive maintenance contract. An

important measure in increasing the availability (in view of the requested plant performance) was to depart from the 3-year maintenance interval used previously and to set up an individual maintenance schedule for each machine. This maintenance schedule takes account of the different applications (sludge properties – also abrasiveness due to the presence of magnesium/aluminium/phosphorus compounds), local operating experience of BWB, daily operating times, as well as experience from other locations.

- Wassmannsdorf: 8,500 operating hours
- Schönerlinde: 10,500 operating hours
- Ruhleben: 8,500 operating hours
- Münchehofe: 12,500 operating hours



Result: Longer maintenance intervals lead to ever deteriorating performance – ultimately to plant failure.

**The maintenance contract comprises:**

- maintenance conducted in rotation,
- service and inspection according to accident prevention regulations (UVV),
- general overhaul, running checks in operation and repairs to rotors and Rotodiff hydraulic drives.

**The following assignment of tasks has proved effective for this work:**

- monitoring of operations by BWB machine operators,
- small-scale inspection, oil change, pe-

ripheral equipment by BWB maintenance and repair staff

- general overhaul, rotor repairs by ANDRITZ
- accident prevention regulations (UVV) by BWB maintenance and repair staff or ANDRITZ

Thanks to this maintenance contract, the costs incurred by the operator for maintenance and repair have not simply remained unchanged, but have actually dropped because the machines were not left in operation until they had to be shut down due to technical or mechanical failure, but were maintained according to the number of operating hours.

**Conclusion**

Due to the amendments to the legal framework for maintenance and safety, operators have more freedom thanks to the individual maintenance intervals introduced. Close and long-term cooperation between operator and equipment supplier allows those involved to define optimum maintenance intervals with minimum risk. With suitable inspection methods and maintenance measures, the operator has cost advantages and can achieve greater availability with the desired separation performance by conducting preventive maintenance work.



◀ The plant wastewater is digested in a treatment plant equivalent to the size of a 250,000 people town. The sludge from a digestion process (biogas is used to produce power for the plant) is dewatered on an ANDRITZ D4 Series decanter centrifuge to high dryness.

## Successful project at Fox River, USA: cost-efficient regeneration of polluted waters

An awareness of environmental protection and sustainability is not only firmly anchored in the minds of the population in the USA, but is also an important topic in American politics and administration. Here, considerable efforts are being made to eliminate existing environmental damage. ANDRITZ is supplying the necessary key technologies for this.

One example of these environmental protection measures in the USA is the project for restoration of the Fox River in Wisconsin, which was polluted in the past by various industries. The deposits on the river bed contaminated with PCB, for example, are to be eliminated by dredging out the sediment and washing out the pollutants.

A consortium headed by Boskalis – Dolman bv of the Netherlands has been commissioned to collect the sediment in the river's course, treat it with chemicals, dispose of the contaminated solids on dumps, and return the water to the river. There are plans to dredge out some 700,000 m<sup>3</sup> of sediment a year, treat it with chemicals, concentrate the material in a static thickener and then dewater it in membrane filter

presses, all over a period of approximately 10 years.



▲ ANDRITZ membrane chamber filter press A4 2000mm x 2000mm with automatic cake discharge

### Key technologies by ANDRITZ

ANDRITZ ENVIRONMENT & PROCESS is responsible for planning, design, manufacture, installation and start-up of the complete dewatering plant. After careful examination by the consortium and the customer, the ANDRITZ A4 2000 membrane filter press was selected as the ideal unit. Eight membrane filter presses of the so-called "stress-less" design, each containing 188 plates of 2 m x 2 m format, dewater around 22 t/h of filter cake per press, with a maximum residual moisture content of 45%. The filter cake is brought to a collection hall on conveyor belts. Two centrifugal pumps in "fail-safe" design are used for each filter press. An automatic water spraying system operating at 100 bar cleans the filter cloths in cycles. The



## 2009 Summary Dredge Production

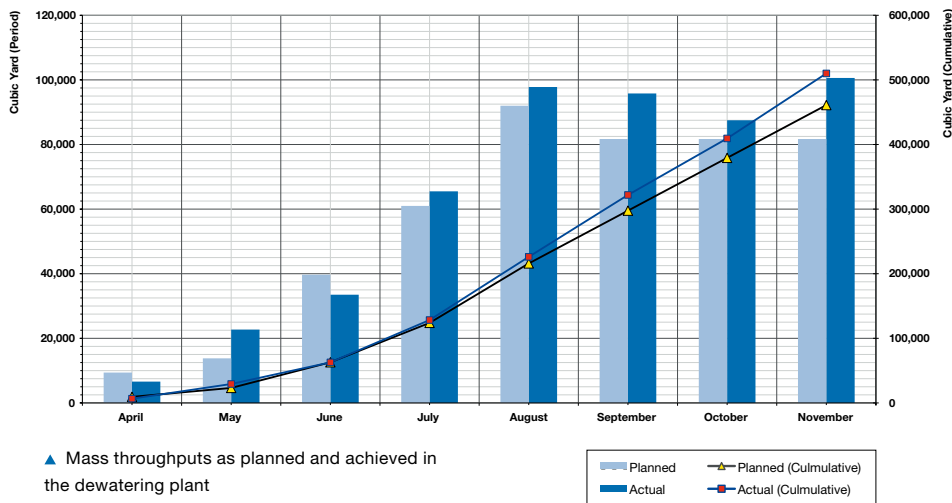

wash water is collected by means of swing valves.

A special feature is the patented cloth spreading device: This allows the filter press to be operated fully automatically without an operator in attendance because the filter cake is discharged automatically by tilting the filter cloths to an angle. An intelligent control system with a hierarchical structure allows the entire plant to be operated from a central control room.

### Start-up ahead of schedule, target values surpassed

The plant was able to start operations before May 1, 2009, the date agreed for start-up in the contract. After only a short period in operation, the planned throughput was surpassed substantially, with the ambitious targets set for the full year in 2009 being exceeded by around 10%.



◀ Central control room of the dewatering plant, with 8 ANDRITZ membrane chamber filter presses

## Comprehensive product portfolio for sludge thickening

**Large wastewater treatment plants require sludge thickening due to an anaerobic digestion phase, with mechanical thickening being the preferred option. For very small WWTPs, mechanical thickening is the best choice in terms of space requirement and storage/transport. In many cases, dewatering is not required.**

The ANDRITZ portfolio includes all the leading technologies for mechanical thickening. The ANDRITZ PowerDrain gravity belt thickener range offers a wide choice of belt widths, for very small (5 m<sup>3</sup>/h) to very large (200 m<sup>3</sup>/h) capacities. Design options include a covered version for odor control and stainless steel frames for optimized design life. Small units can be delivered skid-mounted, which represents a very convenient 'plug-and-play' choice for small plants.

PowerDrum drum thickeners cover capacities from 5 to 90 m<sup>3</sup>/h. The unique design of our PDR900 series ensures optimized performance (adjustable dryness via adjustable drum inclination) as well as a small footprint, fully enclosed operation, and very easy maintenance (belt change).

ANDRITZ centrifuges are an optimized solution for long-term operation as they are the only thickeners that operate without polymers. Our specific thickening scroll design allows 95% solids capture without any chemicals addition. Our CentriCo control system, which is based on thickened sludge dryness measurement, and our Easy-Pond system for automatic pond depth adjustment in operation enable perfect, automatic control of the thickened sludge dryness and, thus, facilitate operation of the anaerobic digester.

## Decanter solutions for biogas production

**Biogas is a clean, renewable form of energy that is produced by anaerobic digestion ('digestion') and has multiple uses, e.g. for heating, power production or as fuel in transport. Since supplying equipment for the first digestion plant using household refuse in 1988, ANDRITZ has been involved in numerous biogas projects of this type.**



The first digestion plant for household refuse in the world was built in Amiens, France, in 1988. Designed by Valorga, a pioneer in anaerobic digestion of household waste, this plant is able to treat 85,000 tons of household waste per year. The digestate from anaerobic digestion is fed to screw presses and the juice passes into hydrocyclones and ANDRITZ decanters. The solid fraction produced is transferred to the aerobic post-treatment unit. Depending on the quality of the waste material, the compost can even be used in farming.

### Specific machine design

Today, ANDRITZ has more than 25 references in biogas production from household refuse, mainly in Europe. Based on its experience and process knowledge in this field, ANDRITZ has designed a decanter centrifuge that specifically meets the requirements of this highly abrasive application.

# Flexible in biofuel production

The 'Renewable Energy' directive adopted by the European Union in April 2009 stipulates that, by 2020, 20% of total energy consumption should be produced from renewable sources. Biofuel is planned to represent a 10% share in transport fuels by 2015. ANDRITZ has been involved in several major bioethanol projects for first as well as second generation bioethanol production.

In first generation bioethanol production from grains, ANDRITZ decanter centrifuges are used in a critical process stage to clarify the whole stillage coming from the distillation columns. The process delivers thin stillage on the one hand and distillers' wet grains on the other hand. Generally, a certain quantity of thin stillage is reused at the beginning of the process and the rest is concentrated and then added to distillers' wet grains before being fed to the dryer. This high protein content by-product is used for animal feeding.

Successful in wheat-to-biofuel applications Tereos, one of the biggest starch and sugar producers and the 4th largest ethanol producer worldwide, started up its Lillebonne, Normandy plant in 2007. This plant produces bioethanol from wheat. Seven ANDRITZ D7 series decanter centrifuges are used to separate the whole stillage from the distillation columns. The Lillebonne plant currently produces three million hectoliters of bioethanol per year.

A new bioethanol plant is currently under construction in the UK. Each year, this plant will produce 4.2 million hectoliters of ethanol. The quality and performance



▲ Seven ANDRITZ D7series decanters at Tereos plant, France

of ANDRITZ's decanter centrifuges convinced the customer to entrust ANDRITZ with the supply of nine D7 series machines.



▲ Five ANDRITZ D7series decanters at Cristanol plant, France

◀ The BENP Lillebonne wheat ethanol plant is strategically located in the heart of France's largest oil refinery industrial complex and close to the port of Le Havre on the Seine River and Atlantic Ocean

plant equipped with ANDRITZ decanters in South Korea. The machines were manufactured in Châteauroux and commissioned in May 2009.

### Second generation bioethanol

Governments and industrial companies worldwide have started to launch research and development projects to produce cellulosic ethanol using materials such as straw or grass as feedstock. Upstream of fermentation steps, such production processes will have to break down the cellulose into fermentable sugars.

Being a technological leader in handling cellulose (based on its Pulp & Paper expertise) and in liquid/solid separation, ANDRITZ is a natural and active partner to these endeavours. Thanks to synergies between the ANDRITZ PULP & PAPER and the ANDRITZ ENVIRONMENT & PROCESS business areas, many projects are currently under way with major global players.

Commissioning will take place by the end of this year.

#### New material: debranned wheat

In 2009, ANDRITZ was selected as equipment supplier for an entirely new biofuel production process: bioethanol from debranned wheat. The innovative customer pursuing the project was Cristanol which is made up of Cristal Union, a major player in the sugar industry, Champagne Céréales, and Chamtor, a starch supplier.

After extensive pilot testing involving three competing suppliers, ANDRITZ was chosen

for this new challenge. Five D7 series decanters were manufactured in Châteauroux and successfully commissioned in March 2009. Today, Cristanol operates two bioethanol lines using debranned wheat to produce a total of 280,000 tons of ethanol per year.

#### Polished rice

In Japan, ANDRITZ was chosen for a project using non-food rice for bioethanol production. Thanks to ANDRITZ's previous experience with such raw materials in Asia, Tsukishima Kikai Co., Ltd. ordered two D5 series centrifuges after visiting a bioethanol

# CentriCo: new control system for centrifuges

CentriCo is a new modular control system for efficient operation of centrifuges developed by ANDRITZ Automation to meet the most demanding operator requirements. It incorporates all the control strategies required to increase sludge quality and reduce operating costs. The system is designed for use in industrial and municipal applications.

The basic version CentriCo SC (single controller) is designed to control the core equipment of a centrifuge:

- Control of VFD bowl and scroll via Modbus or Profibus
- Vibration alarm
- Temperature alarm
- Profibus interface to customer's SCADA system

The expanded version, CentriCo PC (plant controller), is designed to control the core equipment of a centrifuge plus the upstream- and downstream equipment (turnkey installation). In addition to the previous parameters, the CentriCo PC controls the:

- Sludge pump
- Polymer pump
- Interface polymer unit
- Diverter Flap control
- Wash water valve
- Conveyors or cake pumps

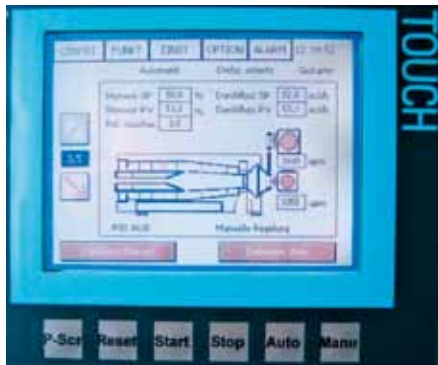

▲ HMI- Operator Panel for a Centrifuge

CentriCo comprises the HMI (Human Machine Interface), a PLC, an interface to MCC, an interface to the SCADA system

of the plant, and a web-based interface for remote control.

## CentriCo benefits for users:

- High resolution graphical user-friendly interface (touch screen)
- Proven PLC and touch screen panel separated for easier maintenance
- Bus connection to higher ranked DCS system
- Remote control of decanter via Ethernet or bus connection
- High flexibility to control a complete dewatering line
- Several types of frequency converters supported (ABB, VACON, LEROY SOMER, Danfoss, etc.)
- The new MPC CentriCo Cost Optimizing tool is now available as an option

## Cost optimizing tool

The cost optimizing CentriCo module has been developed to help customers minimize costs and maximize production of their centrifuges. It is a PC-based linear optimizing software. The communication between the centrifuge controls (up to 20 systems) is done via Ethernet, Profibus or OPC connection.

The operator selects the optimizing target on the operator interface (monitor and keyboard) and enters the actual values of energy, polymer and wear parts costs. According to the actual operating parameters and the selected optimizing target, the system delivers the optimized set values to the connected control systems. The system also provides a suggestion as to how many machines should be operated to reach the selected optimizing target.



▲ Representation on SCADA Screen of customers Plant control

Targets can either relate to cost minimization (energy, polymer consumption, lubrication, wear parts) or production maximization (maximum throughput, optimized dryness).

Based on the adjusted costs and profits, the adjusted target is reached with a mathematical linear optimization program using the characteristic curves of the centrifuges installed.

## Desalination sludge treatment

**Desalination is an expanding market, mainly in the Middle East but also in other areas of the world such as Australia or the Mediterranean countries. In view of strong economic and demographic growth and scarce water resources, these regions are seriously thinking about their drinking water resources and water treatment in general. It is estimated that more than 15 billion dollars will be invested in this field in the next ten years.**

Desalination sludge treatment requires the use of specially designed centrifuges, particularly with regard to the material used. Due to the chloride content of the sludge, ANDRITZ centrifuges for this application are made of Duplex or Superduplex steel. ANDRITZ's references in this field include plants in Australia (Sydney, Gold Coast and Melbourne, one of the largest desalination plants in the world), the Middle East (Fujairah in the United Arab Emirates; Al Dur in Bahrein, Barka II power plant in Oman), and Spain (Barcelona). ANDRITZ's quality and innovation are at the origin of its success.

Drinking water sludge dewatering requires particular expertise with dryness levels being very different from one site to another as the sludge properties depend not only on the water treatment process, but also on the characteristics of the raw water. ANDRITZ offers outstanding competence in drinking water sludge dewatering and tailor-made solutions based on a broad product portfolio comprising centrifuges and filter presses.

# ANDRITZ sludge thickeners for Paris WWTP

The Seine Aval wastewater treatment plant in Paris is the largest plant of its kind in Europe and the second largest worldwide, treating the wastewater from six million inhabitants. Four new ANDRITZ decanter centrifuges will help the operator meet reduced nitrogen levels as of 2011.

Seine Aval has been operated since 1940 by public operator SIAAP who has constantly modified the plant to improve its performance and reduce the impact on the living conditions of the surrounding communities. The plant currently produces 153,000 tons of sludge per year. For new water treatment units installed as from 2003, ANDRITZ delivered two D7L centrifuges for tertiary sludge, four D7LL centrifuges for nitrification sludge thickening, as well as three D5LL-TC centrifuges for "clariflocculation" sludge dewatering.

The European Directive on municipal wastewater treatment dated May 21, 1991 requires European states to reduce nitrogen levels in wastewater by 70% as of 2011. To meet this objective, Seine Aval is currently installing new facilities including a new sludge thickening unit to improve the anaerobic digesters' operation. The unit will be equipped with four D7LL centrifuges including an ANDRITZ Easy-Pond system.

### Constant solids content with Easy-Pond

Easy-Pond is a unique motorized system to adjust pond depth in operation when the conveying torque value alone is too low to control the differential speed (residence time, thus dryness) of the centrifuge. Easy-Pond is coupled with a control loop to ensure constant solids content in the thickened sludge. The solids content is sampled and measured with a specific probe and the value thus determined is compared to the set point, which leads to an adjustment of the pond depth by Easy-Pond and, if need-



▲ Thickening-centrifuges, D7 series, installed for nitrification process

ed, a change of relative speed to increase or decrease the solids' residence time in the rotating unit. This adjustment is carried out fully automatically.



## Sludge treatment **under palm trees**

Wastewater and sludge treatment aren't the first things that come to mind in connection with Palm Jumeirah in Dubai, United Arab Emirates, one of the palm tree-shaped artificial islands that have been created in a gigantic building effort over a ten-year period to increase the area of this small emirate, which has become an ultra-modern commercial metropolis over the past forty years. Nevertheless, Palm Jumeirah needs wastewater treatment as well. Both wastewater treatment plants on the island are equipped with ANDRITZ centrifuges, operating two D4 series and three D7 series machines respectively. Another wastewater treatment plant has been installed on the artificial island of Jebel Ali Palm, for which ANDRITZ has supplied four PowerDrain XL gravity belt thickeners, each with three meters working width.



▲ Projects in Dubai generally require cutting-edge technologies and a high level of expertise, also when it comes to solid/liquid separation. ANDRITZ works together with international contractors to offer customers tailor-made technology for each project.

# New high-performance centrifuge confirms expectations

ANDRITZ has developed a new high-performance centrifuge for municipal applications, the first to undergo an independent comparison.

Two D10LL decanters with a diameter of 910 mm were operated in parallel in a plant near Los Angeles, USA. A decanter with a standard scroll and an electric back-drive system (planetary gear) was compared with a decanter with a new high-performance scroll and a hydraulic back-drive system. In order to guarantee comparability, both the sludge to be dewatered and the polymer emulsion used were exactly the same. The sludge properties were as follows:

### Sludge characteristics

The operating parameters, such as centrifugal acceleration and the liquid level in the centrifuge, i.e. the pond depth, were also the same. The solids separation achieved was over 96% of the suspended solids at all times.

Depending on the feed conditions, such as volume of suspended solids and throughput, the polymer consumption and dryness parameters can provide important information on machine performance.

### Positive results

Compared with the absolute values obtained on the centrifuge with standard scroll, the high-performance centrifuge provides a polymer reduction of around 10 to 15%, an increase in throughput of up to 20% or an increase in dryness of approximately 10%. At the same time, there is an average increase in the required torque of around 20% and a drop of approximately 20% in specific output.

Sludge type	Mixture of primary, biological, and thickened sludge
Suspended solids (SS)	1.92 – 2.04%
Total solids	2.14 – 2.26% dry substance 2,220 – 2,310 mg/l (dissolved solids)
Volatile solids content	58.5 – 59.4%

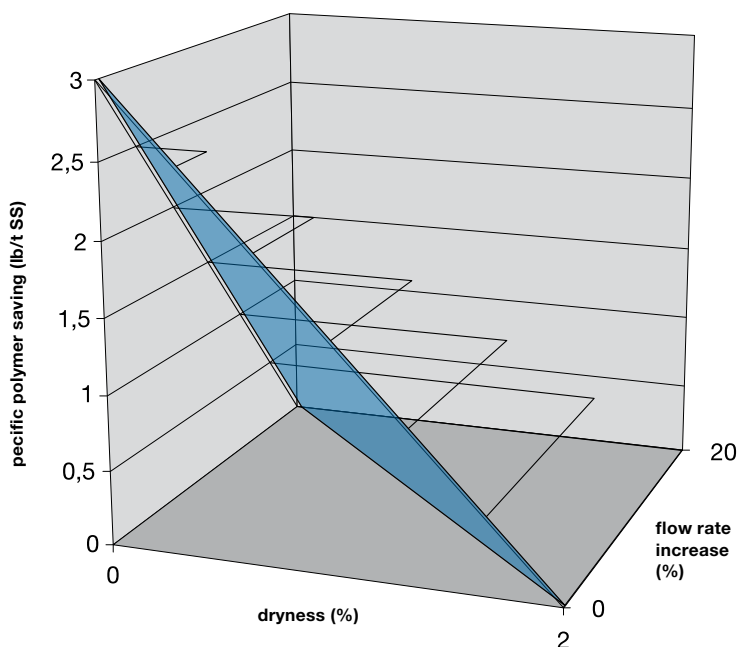

▲ Picture of the tested centrifuge, CA, USA

◀ Connection between increase in absolute dryness, increase in throughput, and reduction in polymer required in the high-performance centrifuge

# New scraping device extends filter cloth lifetime

Although filter presses do not operate continuously (in contrast to centrifuges and belt presses), they are frequently chosen to treat sludge that is difficult to dewater – e.g. drinking water sludge – because they achieve particularly low residual moistures of the filter cake. ANDRITZ has developed and successfully implemented a new scraping device for filter presses that helps to extend the lifetime of the filter cloth compared with unsupported scraping devices as well as increase the specific throughput of the machine.

Chamber or membrane filter presses consist of an assembly of filter plates and filter cloths, a feed system, a collection system for the filtrate, a solids discharge system, and an opening and closing device allowing for the alternating filtration and cake removal steps. The water slurry is pumped into the cavity that is formed between two filter cloths until a maximum pressure of several bars is reached. The liquid passes through the filter media as filtrate whereas the solid material is withheld as filter cake that can be washed and discharged periodically. For this purpose, the filter plates together with the filter cloths are opened to allow the filter cake to fall out before the filter plates are pressed together again and the next batch is pumped into the filter press. To obtain even lower residual cake moisture, membrane filter plates are used instead of standard filter plates. In addition, air blowing systems can be installed to further decrease the residual moisture in incompressible cakes, e.g., minerals.

Today, fully automated operation of filter presses is state-of-the-art. This has been a prerequisite to cope with large sludge volumes. Large specific throughputs are important to keep costs low and, thus, filter presses have been continuously optimized in terms of increasing chamber volumes, installing more chambers per filter press unit, speeding up filling and filtrate discharge, reducing opening and closing cycle times, and ensuring fast and reliable removal of the filter cake. With the thin, sticky cakes typically produced from drinking water and sometimes also from wastewater sludge, complete cake discharge often requires



◀ ANDRITZ membrane filter presses dewater sludge from all types of industries to the highest dry solids possible. A special filter cake scraping device helps meet customers' demands for fully automatic operation. Optimum results are achieved with minimum energy input.

mechanical action, i.e. the cake needs to be scraped off the filter cloth.

### Scraping system with supporting blade

For complete and gentle cake removal, the filter plate must be fixed precisely and the

distance between the scraping blade tip and the filter cloth must be kept constant over the entire filter cloth area. With the ANDRITZ scraping system, this is accomplished by tilting the filter cloth from the filter plate and supporting the filter cloth right



behind the scraper by a supporting blade. The supporting blade bends the filter cloth thus generating a gap to the cake that the scraper dips into, avoiding the need for firm contact with the cloth. This simple, reliable mechanical device guarantees complete filter cake removal; it substantially extends filter media lifetime compared to unsupported scraping devices because a precise distance between the filter cloth and the scraping blade is maintained at all times, and it increases the specific throughput of the machine. Improved synchronization of the two blades and optimized speed profile have resulted in faster performance and more gentle cloth treatment. Optionally, a detection system is available that triggers the action of the scraping device only if the cake does not fall off by itself.

The most recent development is the 3rd generation which encompasses improved synchronization of the two blades and an optimisation of the speed profile of the blades. This has resulted both in faster performance and more gentle cloth treatment. Since only one AC geared motor is used instead of two servo motors to allow vertical positioning of the scraping device, problems with synchronization of the motors are eliminated. Thus a more precise positioning of the scraping device is accomplished with respect to the filter plate. The drive is now accomplished with a chain gear instead of a gear rack. The scraping blade is connected with a shaft that is turned towards the filter cloth hydraulically. The positions of respective hydraulic cylinders are constrained mechanically instead of electrically. The geometry of the scraping and supporting blades is optimized to remove also very thin cakes. Since filter plate location is key for optimal cake removal in an indexing procedure, a new device is implemented that allows proper adjustment of significantly misaligned plates also. The wedges that cause the tilting arms to bridge are now manufactured of stainless steel instead of plastic, which reduces wear and tear considerably. A proximity switch is installed for improved safety. Today, filter cake removal by scraping can be accomplished in approximately 25 seconds



▲ ANDRITZ supplied five fully automatic large-capacity filter presses for water and wastewater treatment in China's largest Industrial Park. Two additional presses have been installed in 2007.

which includes horizontal movement to the respective plate, plate fixing and scraping. Overall, these measures improve performance at comparable or even lower costs.

#### Successful operation

The scraping device has already proved its worth in several ANDRITZ filter presses that are successfully operating in wastewater and drinking water treatment plants. One example of the 1st generation is the municipal wastewater plant in Fürstenfeld, Austria, which has a capacity of approx. 3,000 m<sup>3</sup>/d of wastewater and processes an average 14,800 m<sup>3</sup>/a of biological sludge with a solids content of 2.5-5% generating a product with a solids content of 30% DS when dosing ferric chloride and lime. A filter

press with 70 chambers and a plate size of 1.2 x 1.2 meters has been in operation successfully since 1997. An example of the 2nd generation is the Suzhou drinking water treatment plant in China. This plant has a capacity of around 450,000 m<sup>3</sup>/d of drinking water. On average, 250,000 m<sup>3</sup>/year of sludge is processed producing material with a solids content of 40% DS and an effluent containing less than 30 mg/m<sup>3</sup> solids. The two filter presses used at Suzhou have 120 chambers each and a plate size of 1.5 x 1.5 meters. They have been successfully operating since 2004. Recently 3rd generation scrapers were installed and have been operating successfully in wastewater treatment plants in Slovenia, China, and Belgium.

## Turnkey sludge drying plant for Tilbury

The biosolids drying plant supplied by ANDRITZ for Tilbury wastewater treatment plant in Essex (UK) is designed for a sludge throughput of 18,500 tons of dry solids per year. The sludge is turned into dry granulate containing less than 10% moisture and fulfilling Class A requirements.





This order (value: approximately 38 MEUR) was carried out on a turnkey basis for Anglian Water, one of the leading providers of water and wastewater services in the UK. The plant has been successfully in operation since mid-2008.

### Three types of sludge

Three types of sludge are processed simultaneously by the Tilbury drying plant: SAS (surplus activated sludge) from the Tilbury wastewater treatment works and liquid as well as dewatered sludge from the wastewater treatment works in the surrounding area.

### Energy efficient

Electricity for plant operation is provided by a gas engine operated as CHP unit. Great importance has been attached to efficient heat recovery. Heat is recovered both from the gas engine exhaust gas and the cooling water jacket of the gas engine and reused in the dryer.

As a main contractor, ANDRITZ was responsible for all civil works including building services and for operation of the overall plant during the commissioning, testing, and take-over periods.

### The plant basically consists of following units:

- Sludge reception facilities for 7000 tons of dry solids per year of SAS, 4500 tons of dry solids per year of liquid imported sludge and 7000 tons of dry solids per year of imported dewatered sludge
- Sludge blending & mixing
- Sludge screening
- Batch tanks
- Dewatering by four ANDRITZ D7LL Centrifuges
- Gas engine & heat recovery
- Sludge drying plant (two DDS 70L drum drying lines), each line evaporating a maximum of 7,700 kg/h of water
- Product storage & bagging
- Odour control (biofilter, 2 x RTO)

# Valuable biological waste: belt dryer for fermentation residues

Based on the experience gained with ANDRITZ technologies, a drying plant for fermentation residues has been designed in an exemplary project for the district of Böblingen, Germany.



▲ Belt drying plant for fermentation residues in Leonberg, Germany

When the upstream fermentation plant in Leonberg, Germany, is operating at full capacity, approximately 25,000 tonnes per year of fermentation residues are produced. The fermentation residues from the fermenter are stored in the interim in an intermediate tank before being further processed. Half of the material flow goes to the thermal drying plant. The belt dryer reduces this volume to approximately 7,000 tonnes per year with a dryness of 80 to 90% DS immediately after the drying process. This dried portion is mixed well with the other half of the fermentation residues and is then available for composting.

## ANDRITZ technology: simple and convincing

For conditioning purposes, the fermentation residues are fed to a paddle mixer to be

mixed with some of the material that has already been dried, then spread over the belt by a distribution screw and set to an even layer thickness over the dryer belt. The dryer has a circulating system for the drying air. This enhances the thermal efficiency and reduces the volume of waste air to be treated. The drying air is heated with hot water before it flows through the product layer on the belt, carefully absorbing the moisture from the fermentation residues as it does so.

## Utilizing the waste heat

The thermal energy needed for drying is provided in two different ways. In a first step, the biogas produced during fermentation is converted into electrical energy in a cogeneration unit and a fuel cell. The off-heat from this module in the form of hot water

that would otherwise be wasted provides the heat source for drying the fermentation residues. In a heat exchanger, the hot water transfers its energy to the drying air. In the event that the cogeneration unit and the fuel cell are not in operation, the lack of heat for drying can be substituted by direct use of the biogas from fermentation. In this case, the biogas is incinerated in a combustion chamber and the hot flues gases are mixed with the drying air in order to attain the required inlet temperature for the dryer.

## Utilization of the final product

The composting plant in the district of Böblingen is able to make use of a substantial part of the dried fermentation residues. The remaining volume of dried fermentation residues is used by the waste recycling company to make aged compost. The waste air from the saturator is processed further in a bio-filter. The plant and its equipment comply with all binding occupational health and safety requirements pursuant to the applicable EU directive (ATEX).



With this process, an exemplary concept of waste heat utilisation is used to turn biological waste into a high quality product.

# With **EcoDry** to a sewage treatment plant that is **energy self-sufficient**

Rising energy prices and increasing legal requirements for energy-efficiency require new concepts to generate and supply energy to sewage treatment plants.

In the system network of a sewage treatment plant there are different ways of creating a sewage treatment plant that is energy self-sufficient. The key here is to optimize the overall process with coordinated new and also time-tested individual processes in the sludge treatment sector. An essential component here is to use a low-temperature drying system, and incineration technology that is suitable for burning fuels with a low organic content.

## Making efficient use of the energy content in the sludge

Gas motors are in widespread use to produce electricity from biogas. This process can achieve overall efficiencies (thermal and electrical) of more than 80%, whereas electrical efficiency may be approx. 40%. This process is also a very efficient way of making use of the energy content in the sludge and converting it into electrical energy. Here, it is also important to put the waste heat produced in the exhaust gas circuit from the motor (approx. 400 – 500°C) and in the motor cooling circuit (around 95°C) to good use. Low-temperature drying systems for sewa-



▲ BDS plant in Antalya, Turkey, gas motor + dryer

ge sludge, such as belt dryers, are ideal for this purpose. ANDRITZ has implemented this process successfully in Antalya, Turkey.

European legislation on disposal and utilization of granulate produced is clearly moving towards thermal disposal by incineration. Dewatered sludge can only be incinerated in a stable process with the aid of co-firing, particularly if the sludge has been fully digested. In order to eliminate this cost factor, the sludge has to be dried before incineration. The ANDRITZ EcoDry process provides the best pre-conditions for this. Its simple

cyclone furnace technology is particularly attractive to decentralised plants due to the comparatively low investment involved.

ORC technology, featuring easy operation and good performance at partial load, is also a viable option in decentralised plants for making use of the energy released. In turn, the cooling loop of the ORC process can also be integrated very successfully into the overall plant network when using low temperature drying systems.



▲ EcoDry plant in Eferding, Austria

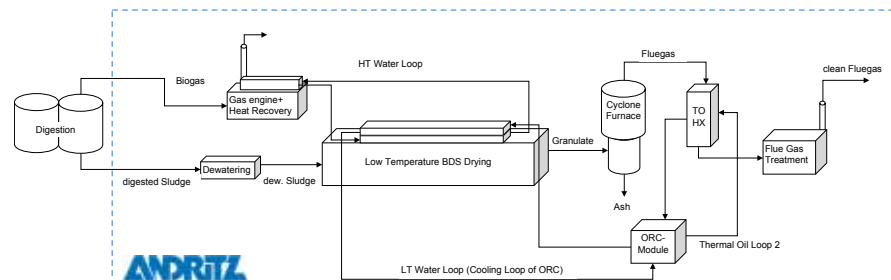

## ▲ Concept for an energy self-sufficient sewage treatment plant

In the overall process shown in the diagram, electrical energy is generated using gas motors and an ORC plant. The heat for the ORC process comes from the cyclone furnace and is provided by the thermal oil loop. The low-temperature belt dryer upstream of the incineration plant is heated partly with hot water (120°C) from utilization of the gas motor waste heat and partly with hot water from the ORC cooling loop.

The electricity demand in a sewage treatment plant can largely be covered with this concept and the sewage sludge disposed of in an environmentally friendly process. Since ANDRITZ can offer the individual units concerned – dewatering, drying, incineration, waste heat utilization – and also has the required technical know-how in planning complete plants and optimizing individual process stages, it is able to provide custom-tailored concepts, up to successful supply of turnkey orders.

# Energy recovery from waste gas in cement production

The ANDRITZ high-grade sludge drying technology provides the cement industry with a new and lucrative business opportunity.

In many cases, a large part of the energy released as waste gas from the rotary kiln in cement production goes to waste. The NUH Cimento works in Hereke, Turkey, is one of the most outstanding examples of innovative ANDRITZ technology, where the sewage sludge is dried using waste heat from cement production and the dried granulate then used as auxiliary fuel to generate heat for cement production.

## No extra cost, no additional CO<sub>2</sub> emissions

NUH Cimento has supply contracts with several neighbouring local authorities for disposal of dewatered sludge (up to 10,400 kg/h, dryness approximately 18 – 30%). The heat requirement for the sludge dryer is covered entirely by the energy recovery process using residual heat from cement production. As a result, there is no need to supply any primary energy, and there are no additional costs for thermal energy used in drying, nor any additional CO<sub>2</sub>-emissions.

With the energy recovered, 2,264 kg of granulate are produced per hour as the residual product of sewage sludge drying and this can be used as fuel (10,000 – 12,000 kJ/kg) for cement production. The entire

heating system for the dryer operates autonomously and thus in no way influences rotary kiln operations. As a result, it can be controlled or shut down as needed without any difficulty. The thermal oil pipework is lined with heat-insulating material so that greater distances between heat source (clinker cooler heat exchanger) and energy consumer (dryer), as is the case in the NUH Cimento works, can be overcome with very little heat loss.

Approximately 643,000 m<sup>3</sup>/hr waste gas at a temperature of around 300°C escapes from the rotary kiln in Line #3 at NUH Cimento. This gas is fed to an electro-filter via a clinker cooler and de-dusted there. Assisted by a fan, approximately 450,000 m<sup>3</sup>/h of waste gas pass through a bypass duct into an air/thermal oil heat exchanger. In the gas-tight heat exchanger, the thermal oil is heated to approximately 190°C for circulating heat transport to the dryer. Two pumps convey the thermal oil to the dryer plant, where the recirculation air from the dryer is heated to 110 – 150°C by several thermal oil/air heat exchangers.

In this way, the belt dryer achieves a water evaporation rate of more than 8 t/hr.



Belt drying plant for sewage sludge in Hereke, Turkey. ►



# Sewage sludge drying: **economical and environmentally friendly**

Sewage sludge drying is constantly changing in order to guarantee safe disposal at all times in compliance with the economic and ecological framework conditions. In the future, thermal processes will gain importance in this field.

Following the ban on dumping sewage sludge, more and more operators are no longer using the sewage sludge as a raw material (due to the planned tightening of legislation on heavy metal content limits for example) and opting more and more for uses in thermal processes. This means that the water contained in the sewage sludge has to be evaporated in each thermal treatment process – either in the process itself (mono-combustion) or in an upstream drying plant, as is the case when added to the fuel used in coal-fired power stations (e.g. coal pulveriser) or cement works. This drying process is energy-intensive because 750 to 900 kWh of thermal energy are needed to evaporate one tonne of water.

## Outdated sewage sludge disposal methods

In Germany, incineration is the most frequently used process for disposal of digested and dewatered sewage sludge, but this provides no or very little energy gain. The digested, dewatered sewage sludge is usually partly dried as it cannot be incinerated without additional energy input until it has a dryness of 40 – 45%. This form of sewage sludge disposal is now outdated because the organic content of the sewage sludge should be used to generate energy, thus preserving natural resources. A drying process upstream of the thermal treatment process is a step in the right direction if



▲ Heimertingen central sewage treatment plant, Memmingen

- the water is evaporated using waste heat from industrial processes (cement kilns, waste incineration, biomass power plants, etc.), and
- the condensation heat, e.g. for heating the digester tower or generating district heating, can usefully be integrated into the water evaporation process.

With sewage sludge drying of the final product of the waste water treatment process, which contains approximately 75% water content, a usable product with a dryness of over 90%, that is biologically stable, having a calorific value comparable to lignite, and graded as being CO<sub>2</sub>-neutral when incinerated, is generated.

Dried sewage sludge is a much sought-after substitute fuel, but its availability is limited due to the lack of drying capacity. As in all thermal processes, drying takes place according to the laws of thermodynamics. The



higher the grade of thermal energy used in terms of input temperature, the more compact the design of the drying plant can be. The optimum solution would be to use primary energy, however this is no longer justifiable from the economic point of view, nor from the viewpoint of careful handling of fuel resources.



### The safety aspects speak in favour of sewage sludge drying plants

The main selection criterion for sewage sludge drying plants is safety. Dried sewage sludge is an organic material with the following product properties:

- combustible
- calorific value comparable to lignite
- tends to self-ignite
- formation of explosive dust and air mixtures.

The properties of the dried sewage sludge determine the safety requirements of the drying process and handling of the dry material! The solution to ensuring safe operations in drying plants is

- reliable exclusion of at least one of the three requirements for a dust explosion (dust, oxygen, ignition energy)
- consistent use of the safety equipment already known from the chemical and fuel industries also in sewage sludge drying plants.

Consistent operations under inert gas conditions in all operating modes, as practised



▲ Shanghai sewage treatment plant, Bailonggang, during the building phase

successfully in fluidized bed drying plants for over two decades, leaves no leeway for explosive mixtures to form. Air is always a risk factor in treating organic substances. A low drying temperature only appears to lower the probability of fire and explosion, however a careful analysis (ATEX) based on operating experience in sewage sludge drying plants, particularly in run-up and shut-down processes and during malfunctions, is indispensable.

Apart from the safety aspects, the following criteria are important in selecting sewage sludge drying equipment:

1. Availability for more than 7,500 operating hours per year, i.e. like all thermal plants, sewage sludge drying plants run in continuous operation only and can be only be run economically with high capacity utilization.
2. A product in granulate form with low dust content and dryness of >90% is preferable in order to obtain a biologically stable product that is easy to store and transport so that the dried sewage sludge can be brought to the thermal disposal plant.
3. The excess gases from the drying process that emit unpleasant odours should be kept to a minimum with an air-tight plant design and effective gas treatment plant.

### Drying in the sewage treatment plant by utilizing digester gas

In Germany's sewage treatment plants, the classic solution is to use digester gas



◀ Shanghai sewage treatment plant, Bailonggang, during the building phase

to generate electricity in gas motors and use the waste heat to heat the digester. Increasingly, however, operators are considering whether the “green” and frequently promoted power generation from digester gas would not be more effective if replaced by thermal utilization of the digester gas in sewage sludge drying. The gas motor has an electrical efficiency of 40% at the most, while the remaining 60% of waste heat is generally only used to a small extent – depending on the time of year – to heat the digester. A thermal oil boiler for heating a sewage sludge drying plant achieves thermal efficiency in excess of 90% without a huge technical effort.

As the fluidized bed drying plants in Germany (Göppingen und Memmingen), Switzerland or China show, the sludges produced can be dried easily with the gases generated in the digesting process without requiring any primary energy if the sludge has a dryness of >25% after mechanical dewatering. The digester is heated using the waste heat from the sewage sludge drying plant.



### Drying in industrial processes using the waste heat generated

A clever energy combination is to use the waste heat in a cement kiln and a sewage sludge dryer. The concept realized in Karlstadt cement works, Germany, and in Hereke (Turkey, see also report on page 30) reduces the costs for thermal energy to a minimum. The energy combination used successfully in cement production can also be applied to other thermal processes, such as coal-fired power plants or refuse incineration plants. The fluidized bed drying plant in Houthalen-Helchteren, Belgium, that went into operation in 2001 dries de-



▲ Sewage Sludge Drying Plant in Loeches, Madrid, Spain

watered sewage sludge from more than 30 different sewage treatment plants. The fluidized bed dryer used here is supplied with heating steam from the refuse incineration plant located nearby. The granulate, with a dryness of around 92%, is used as fuel substitute for hard coal in the neighbouring coal-fired power station. The fluidized bed drying technology in use also features a tried-and-tested operating and safety concept. The digested and undigested sewage sludge to be treated, with dryness of 18 to 30%, is fed directly to the dryer without any pre-treatment, then granulated and dried at 85°C in a virtually oxygen-free gas. Consistent operation of the drying plant is a key requirement for achieving approximately 8,000 operating hours annually at full load. The optimum energy combination created here improves the cost situation for:

- the waste-to-energy plant due to the improved power and heat combination,
- Aquafin as operator of the sewage treat-

ment plant due to improved sludge disposal, and

- the coal-fired power station by using a substitute for hard coal and due to the improved CO<sub>2</sub> balance.

### Utilization of waste heat from cogeneration units

In Spain, gas motors fired with natural gas went into operation in combination with sewage sludge drying plants with the aim of achieving overall energy efficiency of >90%. The drying plant in Rubi near Barcelona, with water evaporation output of 3 t/h, has been operating according to this concept since 2001. In 2010, a further fluidized bed drying plant with two lines providing a water evaporation output of 10 t/h will go into operation in Loeches, near Madrid. The heat required to evaporate the sewage sludge water is provided by the waste heat from three gas motors and brought to the fluidized bed dryers by means of thermal oil.

# Fully encased belt drying plant for Nufri

The new generation ANDRITZ belt dryers with full concrete casing constitute a very safe and energy efficient solution also for large drying projects as implemented for Nufri in Mollerussa, Lleida, Spain.

Nufri is one of the leading Spanish food industry groups in the horticultural and fruit sectors. The company philosophy, which made Nufri one of the most successful groups in its line in a very short time, is based on the use of most advanced technology in all areas including environmental protection.

## Encased system for a large-scale project

The drying system implemented for Nufri is a newly developed and patented low temperature belt dryer for 3.9 t/h of water evaporation, heated with warm and hot water. This new belt dryer generation uses a special combined concrete and stainless steel design which offers unique advantages with regard to corrosion resistance under adverse weather conditions. No additional building for the dryer is required; all mechanical parts, such as feed modules, belt drive and rolls, belt guidance, as well as the discharge system are integrated into the concrete structure as preassembled modules. The sludge feed and the dosing bin, mixing screw and return system are mounted on the longitudinal side of the casing.

## Use of exhaust air

The necessary power and heat are produced in a combined cycle power plant. Biogas from the digester of the factory's wastewater treatment plant and natural gas are used as fuels for the gas motors. Primary power is produced by five gas motors with a capacity of 2.7 MW each. The exhaust gases from these gas motors with a temperature of approximately 450-500°C are utilized to produce steam which serves for additional power production in a steam turbine to boost the efficiency of the combined cycle power plant. Implementation of the cogeneration plant is in line with Nufri's strategy to use latest technology and strive for environmental sustainability.

The hot flue gases leaving the steam boiler at a temperature of approximately 180°C are reused to produce hot water with a temperature of up to 140°C and warm water of up to 95°C. The ANDRITZ belt drying technology can use the hot and warm water as a heat source for drying the sludge from Nufri's wastewater treatment plant, as well as sludge from other sewage treatment plants.



▲ Belt dryer in full concrete casing

## Safety engineering

Safety is a high priority in drying plants. Belt drying provides a high safety level by nature because temperatures and dust concentrations are comparatively low. In addition, extensive HAZOP studies were conducted and safety engineering measures implemented to ensure the plant and equipment are in full compliance with the ATEX directive.



# ANDRITZ supplies the world's largest belt dryers for biomass with **eight metres belt width**

High performance and top quality make ANDRITZ belt dryers the first choice for clients in industry.



In June 2009, two ANDRITZ belt dryers went into operation at Heggenstaller sawmill in Lauterbach, Germany. The dried sawdust is used both in pallet block manufacture and in wood pellets production, which is to begin in 2010.

Around 800,000 solid cubic meters – spruce and pine for structural and packaging timber – are to be processed in three-shift operations as from 2011. In order to create a location that is well integrated, the company invested in a pallet block production system in addition to the sawmill.

## **'ANDRITZ offers the best technical alternative'**

For a company of our size, ANDRITZ offers

the best technical alternative. ANDRITZ has a great deal of experience, particularly in industrial applications', explains Gebhard Dünser, Heggenstaller's managing director. 'We installed the first belt dryer back in 1997. So we know what lines of this dimension have to accomplish and thus, set stringent demands on the supplier. ANDRITZ was able to meet these demands.' The process design is also very clever in terms of the entire process control, according to Dünser. For instance, the drying process in the ANDRITZ equipment is controlled via the saturation level in the air and not just the moisture content in the wood chips. The plant installed at Heggenstaller consists of two BDS SI 130-40x8 belt drying systems each with a water evaporation capacity of

around 11 t/h. The entire design of the plant adheres strictly to all relevant EU directives, in particular ATEX (94/9/EC).

## **Operating around the clock**

The wet sawdust coming from the log conversion line on a pipe conveyor is stored in a silo. With a diameter of 15 m and a useful volume of 4,500 m<sup>3</sup>, the silo acts as a buffer store between the working hours of the sawmill. Thus, the belt dryers can be supplied continuously – also at weekends.

## **Drying on eight metres operating width**

The sawdust is fed into two symmetrically arranged augers, which ensure that the material to be dried is spread at an even height over the entire dryer belt width. The



### In-house power supply

The thermal energy needed for drying is provided by waste heat from the biomass power plant. Thus, the drying plant is very well integrated into the location's energy network. The utilisation of hot water at a low temperature level (below 70°C) makes considerable demands on the plant.



▲ Fans

thus achieving a maximum fluctuation range of  $\pm 0.5$  percentage points.

### Advantage of the system

The ANDRITZ belt dryer features a modular design, making it easy to operate and also service-friendly. The modular design ensures short assembly times, while the fully developed process and automation technology allow shorter start-up times and an operator-friendly production process. In addition, belt dryers are suitable for low-temperature energy. The wet sawdust feed is controlled by means of a special level measuring device in the feed module, which ensures optimum material feed onto the belt. The volume of drying air can be adjusted via the fans.

### ANDRITZ belt dryers have the following special mechanical features:

- The solid steel construction of the dryer makes it suitable for holding components, platforms, pipework, and walkways.
- All screw conveyors and built-in parts are designed for easy removal.
- The frost-protected sawdust feeder system offers various adjustment facilities.
- No rotating parts have been used in the belt support and dryer housing.
- Special attention has been paid to creating a water-saving belt cleaning system.
- Extremely long belt tensioning range for easy belt mounting and for the temperature – time- stretching – tensioning properties of the belt.
- Automatic belt guiding system.
- Solid, adjustable belt tensioning device for central belt running.
- Rubber-covered drive and regulating roll, deflection roll with special coating.
- The anti-static belt is designed with an endless butt connection.

belt conveys the material through the dryer, where it is heated by means of hot air and dried in the process. At the end of the belt, a screw discharger transfers the sawdust to the onward conveying elements. The belt width is 8 m. The belt dryers available on the market to date were limited to a belt width of 6 m. This new width permits a higher output, but also makes stringent demands on the design of the plant's mechanical parts. The drying air is heated indirectly with hot water by a suitable number of heat exchangers, arranged on two levels above the belt. The heated air flows through the material to be dried and absorbs the moisture as it does so. The fans required in this process are mounted along one side of the dryer housing.

In terms of energy costs, ANDRITZ guarantees low electricity consumption per tonne of material dried with this technology.

The quality requirements of the dried material need a low, but constant residual moisture content with a minimum of fluctuation. The sawdust has a moisture content of  $8\% \pm 1\%$  when it enters the dry sawdust silo and then the pallet block production plant.

The belt dryer can dry it to a moisture content as low as 2%. In order to satisfy these requirements in spite of fluctuations in raw material and in energy supply, a special control concept was developed for the drying plant.

The dried sawdust moisture content and the air saturation are measured continuously in order to keep fluctuations in the sawdust moisture content to a minimum,

# Safety in drying plants

The safety engineering requirements for plant and machinery were again extended when the new machine directive 2006/42/EC was introduced and a series of harmonised standards were added

The EU now attaches special importance to the comprehensive risk analysis for plants, particularly to possible faults as a result of human operating errors. By doing so, it is responding to practical experience because damage to plants is actually caused primarily by carelessness, lack of experience or training of the operating personnel, or due to insufficient qualification.

## Top priorities in safety

In addition to complying with the relevant standards, ANDRITZ has set itself the task of focussing on safety engineering in drying plants. The top priorities here are:

- automating as many operating procedures as possible and thus restricting the amount of manual intervention required.
- manual operation for single machines only and safety interlockings also in this operating mode wherever possible.
- full monitoring and alarm procedure in the event of deviations from the norm, also during plant shutdowns.
- safety functions must remain active in every operating mode, i.e. also during plant shutdown.

In order to assist the operating personnel during operation, and particularly during breakdowns, ANDRITZ offers the following:

- exact documentation with clear instructions for plant operation.
- specifications for brief and precise safety instructions.
- precise instructions for emergency procedures.
- intensive training focussing on deviations from normal operations, service work, and dangerous situations in manual operation.

## Belt drying: special demands on safety engineering

The lower operating temperature of belt dryers, which normally operate in the drying zone at between 100 and 150°C, means that there is only a small risk of a spontaneous combustion reaction, material overheating, fire, or explosion. Nevertheless, the ATEX guidelines must also be followed here, i.e. classification of hazardous areas and source of ignition analyses must be conducted with care.

The risk of dust deposits in the dryer exceeding the usual 5 mm dust layer is often underestimated. This can cause the minimum ignition temperature to drop sharply

(to around 100°C and less) – and if the dust is also dispersed just as a hot spot has formed, a fire may occur or even an explosion in extreme cases.

So far, little attention has been paid in sewage sludge drying to the influence of iron compounds in the sludge, which are being used more and more in the form of iron chloride or iron sulphate as precipitation agents or to reduce odours from hydrogen sulphide compounds during sewage treatment. Experience shows that an iron content of only approximately 2% by weight in relation to the dryness can have a substantial negative impact on self-ignition behaviour (in some plants the iron content may even be as much as 10 to 15% by weight!). This has most impact during interim storage or silo storage of the dried granulate, or in the dryer itself if it is shut down for a longer period without being emptied. Since the iron compounds that are present reduce the self-ignition temperature, hot spots may form in the granulate deposits that can

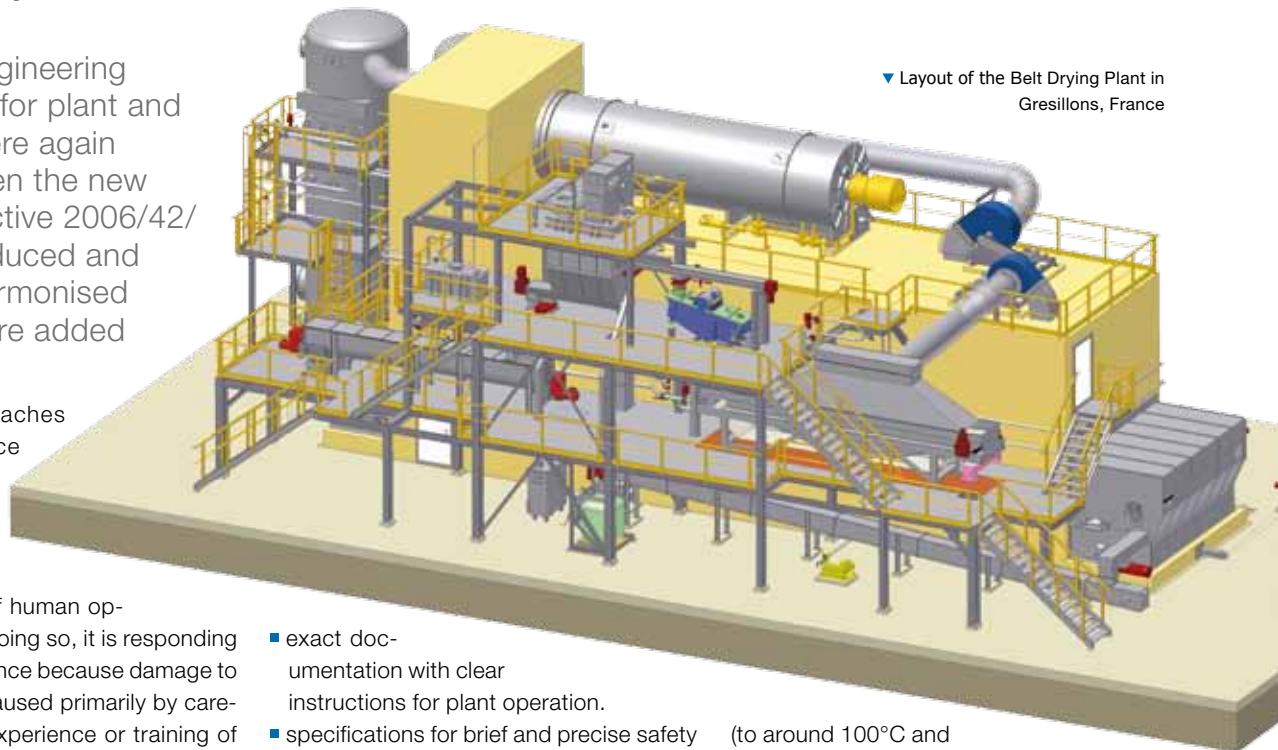

▼ Layout of the Belt Drying Plant in Gresillons, France

lead to fire if they are not detected in time.

Although the dust content in the dryer is below the lower explosion limit by a factor of 1,000 due to the large volumes of air present during normal operations, it is important to monitor dust concentrations in order to avoid creating a potentially explosive atmosphere and to detect any changes right from the outset, caused by damage to the belt or leaks in the dryer, and to shut the plant down safely.

It is vital to identify deviations from normal operations right away so that the appropriate measures can be set in motion. ANDRITZ belt dryers are thus fitted with

several temperature, CO, and dust sensors that monitor all areas inside the dryer, the air surrounding the dryer, and the dryer exhaust air.

**‘Safety box’: the extra safety level**

Alarms are given if limit values are exceeded, and at specific alarms threshold, the plant is shut down and extinguishers are activated (sprinkler system above the belt). Since these safety measures are normally initiated by means of a simple SPS control unit, ANDRITZ has created an additional safety level that operates independently of the plant control system and is known as the ‘Safety box’. This safety-oriented control system operates completely independently of the control system and monitors all safety-critical parameters, such as dust,

temperatures and CO levels. If the limit values are exceeded, this control system shuts the plant down immediately and initiates fire extinguishing by the sprinkler system. In addition, the “Safety box” monitors the availability of extinguishing water and prevents the plant from starting up if the water supply is inadequate. As it is highly reliable, the ‘Safety box’ is assigned to SIL (Safety Integrity Level) category 2, i.e. the box has very low failure probability and is thus authorised for use in special safety tasks.

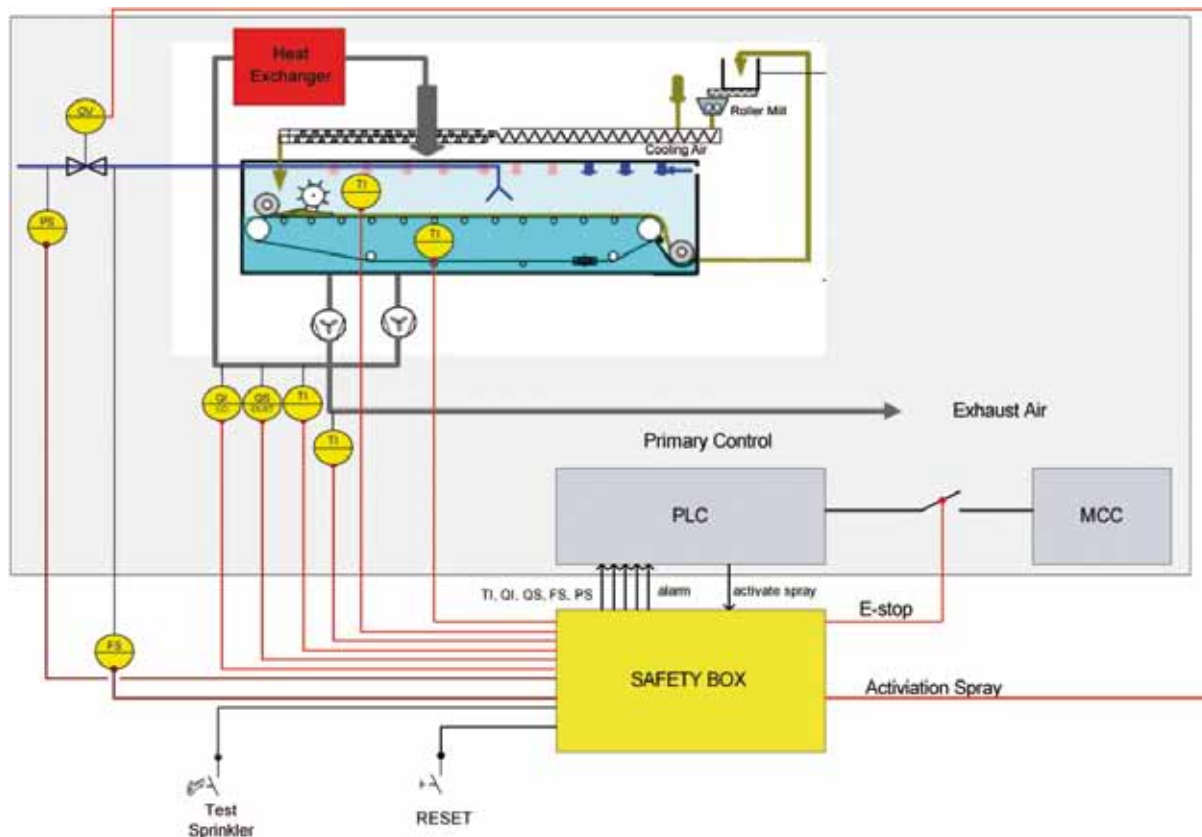

◀ Diagram showing the safety sensor system



## Always at your disposal – all around the world!

### GERMANY

#### **ANDRITZ Fließbett Systeme GmbH**

Phone: +49 (751) 56058 0  
 Fax: +49 (751) 56058 930  
 environ.de@andritz.com

#### **ANDRITZ Separation GmbH**

Phone: +49 (221) 9856 107  
 Fax: +49 (221) 9856 202  
 separation.de@andritz.com

### FRANCE

#### **ANDRITZ S.A.S.**

Phone: +33 (139) 2605 50  
 Fax: +33 (139) 2605 60  
 environ.fr@andritz.com  
 separation.fr@andritz.com

### GREAT BRITAIN

#### **ANDRITZ Ltd.**

Thermal Processes  
 Phone: +44 (1773) 599 540  
 Fax: +44 (1773) 599 541  
 environ.uk@andritz.com

#### **ANDRITZ Ltd.**

R&B Technology Center  
 Phone: +44 (1782) 5656 56  
 Fax: +44 (1782) 5661 30  
 separation.uk@andritz.com

### SWITZERLAND

#### **ANDRITZ AG**

Office Wohlen  
 Phone: +41 (56) 618 4680  
 Fax: +41 (56) 618 4681  
 environ.ch@andritz.com

### RUSSIA

#### **ANDRITZ Rep. Office Moscow**

Phone: +7 (499) 75091 82  
 Fax: +7 (499) 750 9186  
 separation.msk@andritz.com

### SPAIN

#### **ANDRITZ Ingeniería S.A.**

Phone: +34 (91) 663 6409  
 Fax: +34 (91) 651 1931  
 environ.es@andritz.com  
 separation.es@andritz.com

### USA

#### **ANDRITZ Separation Inc.**

Phone: +1 (817) 465 5611  
 Fax: +1 (817) 468 3961  
 environ.us@andritz.com  
 separation.us@andritz.com

### CHINA

#### **ANDRITZ Technologies Ltd.**

Phone: +86 (10) 6561 3388  
 Fax: +86 (10) 6500 6413  
 environ.cn@andritz.com

#### **ANDRITZ Technologies Ltd.**

Phone: +86 (757) 8296 9222  
 Fax: +86 (757) 8296 9289  
 separation.cn@andritz.com

### BRAZIL

#### **ANDRITZ Separation Ltda.**

Phone: +55 (11) 2168 0130  
 Fax: +55 (11) 2168 0120  
 environ.br@andritz.com

#### **ANDRITZ Separation Indústria e Comércio de Equipamentos de Filtracao Ltda.**

Phone: +55 (47) 3387 9100  
 Fax: +55 (47) 3387 9103  
 separation.bra@andritz.com

### CHILE

#### **ANDRITZ Chile Ltda.**

Phone: +56 (2) 462 4600  
 Fax: +56 (2) 462 4646  
 separation.cl@andritz.com

### SINGAPORE

#### **ANDRITZ Singapore Pte. Ltd.**

Phone: +65 (6512) 1800  
 Fax: +65 (6863) 4482  
 environ.sg@andritz.com  
 separation.sg@andritz.com

### AUSTRALIA

#### **ANDRITZ PTY LTD**

Phone: +61 (2) 4914 4000  
 Fax: +61 (2) 4955 3788  
 environ.au@andritz.com  
 separation.au@andritz.com

### SOUTH AFRICA

#### **ANDRITZ (Pty) Ltd**

Phone: +27 (11) 455 0107  
 Fax: +27 (11) 455 0146  
 separation.za@andritz.com

### INDIA

#### **ANDRITZ Separation (India) Private Ltd.**

Phone: +91 (44) 4399 1111  
 Fax: +94 (44) 2653 5103  
 separation.in@andritz.com

### AUSTRIA

#### **ANDRITZ AG**

Phone: +43 (316) 6902 2990/2318  
 Fax: +43 (316) 6902 453/463  
 environ@andritz.com  
 separation@andritz.com  
**www.andritz.com**