

Generator set noise solutions: Controlling unwanted noise from on-site power systems

> White Paper

By Dennis Aaberg, Senior Acoustics Specialist



Our energy working for you.™

With the growth of standby, prime and peaking power installations in highly populated areas, design engineers have focused their attention on understanding how generator set noise is propagated and controlled. The high cost of retrofitting a site for noise reduction makes it imperative to assess noise performance requirements early in the on-site power system design stage. By applying the principles outlined in this paper, power system designers and end users alike will be able to more easily control unwanted noise from their on-site power system.

Like many types of rotating machinery, reciprocating engine-powered generator sets produce noise and vibration. Whether these generator sets run continuously in prime power applications or only occasionally in standby applications, their operating sound levels often must be reduced to comply with local, state or federal ordinances. In North America, maximum permitted overall noise levels range from 45 dB(A) to 72 dB(A), depending on location and zoning. In fact, recently, some states and communities have begun to specify property line noise restrictions using octave band frequencies to reduce the amount of low-frequency noise that reaches community neighborhoods. Since untreated generator set noise levels can approach 100 dB(A) or more, both the location of the generator set and noise mitigation take on great importance.

In general, two forms of regulations affect the volume of noise to which individuals or the public may be exposed: state or municipal noise ordinances and Occupational Safety and Health Administration (OSHA) federal safety regulations. The former regulations address noise that may migrate beyond property lines and disturb the public but that is seldom sufficiently loud to constitute a safety hazard. The latter addresses standards for noise exposure in the workplace to protect the health of workers. OSHA regulations normally only apply to workers who may be exposed to generator set noise that is above 80 dB(A) for any appreciable time. Workers can limit exposure by wearing proper hearing protection when working around operating generator sets. Europe and Japan, as well as numerous other countries, have also set standards to control noise in the workplace and in the environment at large.

Defining noise

Sound is what the human ear hears; noise is simply unwanted sound. Sound is produced by vibrating objects and reaches the listener's ear as pressure waves in the air or other media. Sound is technically a variation in pressure in the region adjacent to the ear. When the amount of sound becomes uncomfortable or annoying, it means that the variations in air pressure near the ear have reached too high an amplitude.

The human ear has such a wide dynamic range that the decibel (dB) scale was devised to express sound levels. The dB scale is logarithmic because the ratio between the softest sound the ear can detect and the loudest sound it can experience without damage is roughly a million to one or 1:106. By using a base-10

logarithmic scale, the whole range of human hearing can be described by a more convenient number that ranges from 0 dB (threshold of normal hearing) to 140 dB (the threshold of pain).

There are two dB scales: A and L.

- The dB(L) unit is a linear scale that treats all audible frequencies as having equal value. However, the human ear does not experience all sound frequencies as equally loud. The ear is particularly sensitive to frequencies in the range of 1,000 to 4,000 Hertz (cycles per second), and not as sensitive to sounds in the lower or higher frequencies.
- Therefore, the “A-weighting filter,” which is an approximation of loudness, is used to correct the sound pressure levels to more accurately reflect what the human ear perceives. This frequency-weighting results in the dB(A) scale, which was adopted by OSHA in 1972 as the official regulated sound level descriptor.

Figure 1 shows typical noise levels associated with various surroundings and noise sources.

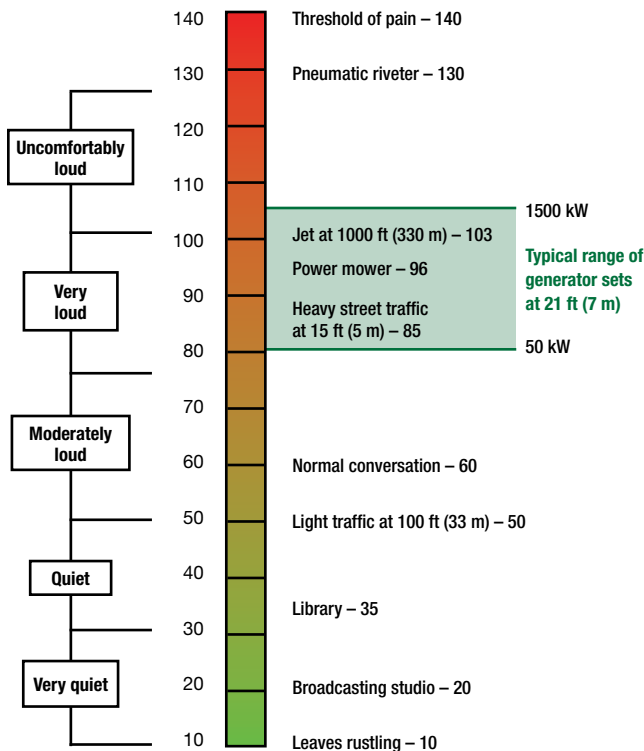

Figure 1: Typical noise levels

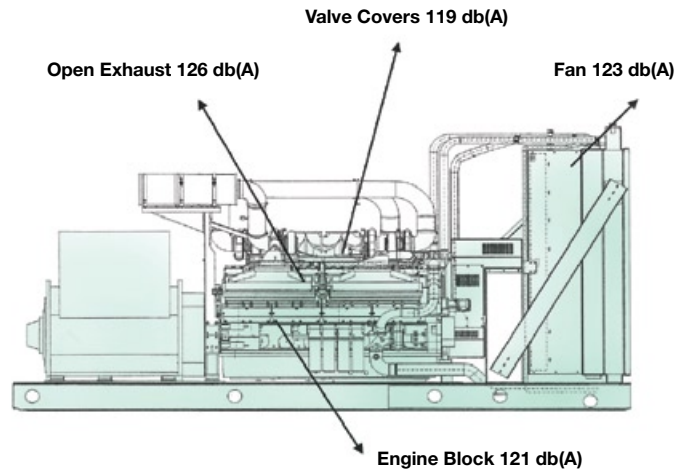

Figure 2: 2000 DQKC noise sources (estimated sound power levels)

Sources of generator set noise

Generator set noise is produced by six major sources (see Figure 2):

- Engine noise – This is mainly caused by mechanical and combustion forces and typically ranges from 100 dB(A) to 121 dB(A), measured at one meter, depending on the size of the engine.
- Cooling fan noise – This results from the sound of air being moved at high speed across the engine and through the radiator. Its level ranges from 100 dB(A) to 105 (A) dB at one meter.
- Alternator noise – This is caused by cooling air and brush friction and ranges from approximately 80 dB(A) to 90 dB(A) at one meter.
- Induction noise – This is caused by fluctuations in current in the alternator windings that give rise to mechanical noise that ranges from 80 dB(A) to 90 dB(A) at one meter.
- Engine exhaust – Without an exhaust silencer, this ranges from 120 dB(A) to 130 dB(A) or more and is usually reduced by a minimum of 15 dB(A) with a standard silencer.
- Structural/mechanical noise – This is caused by mechanical vibration of various structural parts and components that is radiated as sound.

Measuring noise

Before you can begin to determine what mitigation might be required, you have to collect accurate sound measurements of both the existing ambient noise and the noise contributed by the generator set. Accurate and meaningful generator set sound-level data should be measured in a “free field environment.” A free field, as distinguished from a “reverberant field,” is a sound field in which there are negligible effects from sound being reflected from obstacles or boundaries. Noise measurements should be made using a sound level meter and an octave band filter set, at a minimum, to allow for more detailed analysis by acoustical consultants.

When measuring sound levels from a distance of 7 meters, microphones are placed in a circular array with measurement locations at 45-degree increments around the generator set. The measurement array is 7 meters from an imaginary parallelepiped that just encloses the generator set, which is usually defined by the footprint dimensions of the skid base or chassis.

When measuring sound power levels for European applications, a parallelepiped microphone array is typically used, as defined in International Standards Organization standard ISO 3744.

Sound performance data for generator sets from Cummins Power Generation Inc. are available on the company’s design software CD (called “Power Suite”). Sound performance data is also available in the Power Suite Library on the company’s Web site: www.cumminspower.com.

Initial noise measurements are usually made in eight octave bands from 63 Hertz to 8000 Hertz, although the highest sound power generated is typically in the range of 1,000 Hertz to 4,000 Hertz – the range of sound to which the human ear is most sensitive. While measurements are taken across a spectrum of frequencies, the logarithmic sum of all the frequencies is the most important reading. However, when the overall sound level exceeds the allowable level for a project, frequency band data is used to determine what design changes are necessary to lower the overall sound level to comply with requirements.

Totaling all the sources of noise

The total noise level from a generator set is the sum of all the individual sources, regardless of frequency. However, because the dB(A) scale is logarithmic, the individual dB(A) readings cannot be added or subtracted in the usual arithmetic way. For example, if one noise source produces 90 dB(A) and a second noise source also produces 90 dB(A), the total amount of noise produced is 93 dB(A) – not 180 dB(A). An increase of 3 dB(A) represents a doubling of the sound power; yet, this increase is barely perceptible to the human ear.

Figure 3 illustrates how to add decibels based on the numerical difference between two noise levels. As in the example above, if there is no difference between noise source 1 and noise source 2, their combined dB(A) measurement would only increase by 3 dB(A) – from 90 dB(A) to 93 dB(A). If source 1 was 100 dB(A) and source 2 was 95 dB(A), their combined dB(A) measurement would be 101 dB(A).

How to add decibels	
When the numerical difference in dB(A) between two noise levels is:	Add this dB(A) amount to the higher of the two noise levels for a total:
0	3
0.1-0.9	2.5
1.0-2.4	2
2.4-4.0	1.5
4.1-6.0	1
6.1-10	0.5
10	0

Figure 3: How to add decibels based on the numerical dB(A) difference between two sources.

Noise laws and regulations

In North America, state and local codes establish maximum noise levels that are permitted at the property line. Figure 4 shows some representative outdoor noise level regulations. Compliance with these noise regulations requires an understanding of the existing ambient noise level at the property line without the generator set running and what the resultant noise level will ultimately be with the generator set running at full load.

Noise Zones:	Peak Daytime db(A)	Peak Nighttime db(A)	Continuous Daytime db(A)	Continuous Nighttime db(A)
Urban – Residential	62	52	57	47
Suburban – Residential	57	47	52	42
Very Quiet Suburban or Rural Residential	52	42	47	37
Urban – Nearby Industry	67	57	62	52
Heavy Industry	72	62	67	57

Figure 4: Representative outdoor noise level regulations

In Europe, regulation of generator noise is governed by the 2000/14/EC (Stage II) legislation that has been in place since 2006. For generators with a prime power rating less than 400 kW, the maximum sound power level permitted is calculated using the formula:

$$95 + \text{Log } P_{el} = \text{dB(A)}$$

(where P_{el} is the generator's prime power rating)

Generators of 400 kW prime rating and above are only required to be labeled with the LWA figure (European measurement of "acoustic power level") calculated from the manufacturer's developmental test results. For the European market, most generators from 11 kVA to 550 kVA are packaged in standard enclosures that make

the units compliant with most legislation. Standard enclosures typically reduce radiated noise by a minimum of 10 dB(A).

Strategies for reducing generator set noise

Regardless of the type of generator set that needs sound attenuation, there are basically seven strategies for reducing generator set noise: 1) reduce the sound level of the source; 2) acoustic barriers; 3) acoustic insulation; 4) isolation mounts; 5) cooling air attenuation; 6) exhaust silencers; and 7) efforts to maximize the distance between the generator set and the property line (or people). When locating generator sets outdoors, the use of enclosures – particularly sound-attenuating enclosures – combines all of these strategies into a convenient package that provides weather protection as well as sound attenuation. These strategies are summarized in Figure 5.

1. Acoustic barriers – Rigid materials with significant mass and stiffness reduce the transmission of sound. Examples include sheet steel typical of enclosures, and concrete- or sand-filled block walls or solid concrete walls typical of indoor generator room installations. It is also important to eliminate sound paths through cracks in doors or walls, or through access points for exhaust, fuel or electrical wiring.

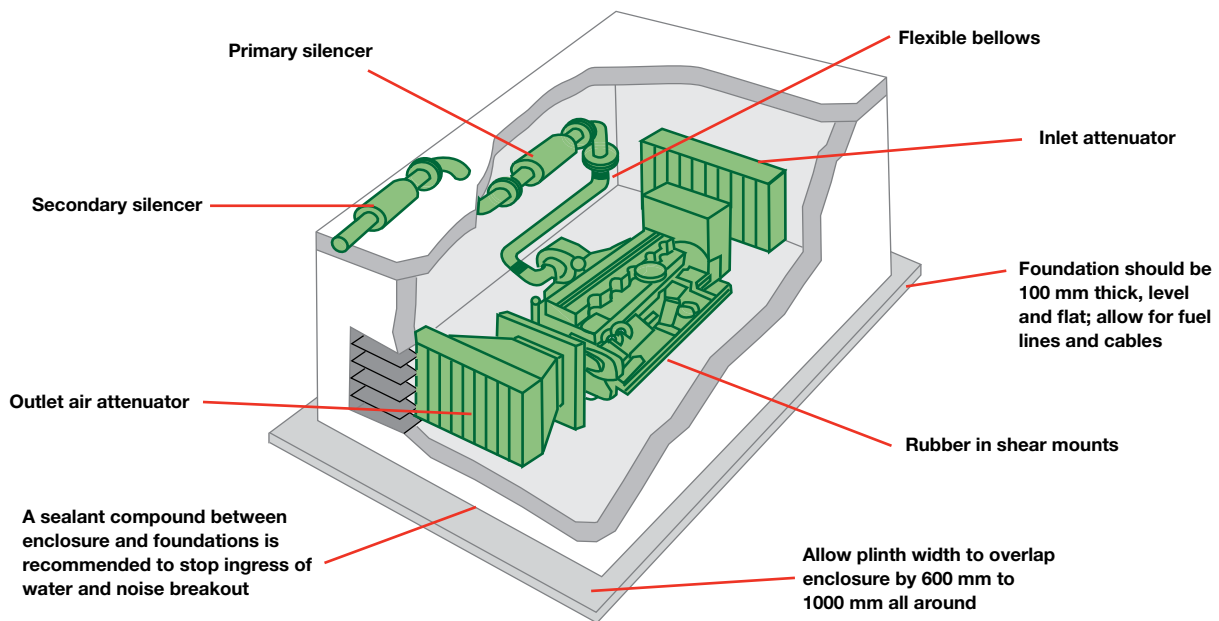

Figure 5: Typical genset installation showing noise control measures

2. Acoustic insulation – Sound-absorbing materials are available for lining air ducts and covering walls and ceilings. Directing noise at a wall covered in sound-absorbing material can be very effective. Select materials that are resistant to oil and other engine contaminants. Fiberglass or foam may be suitable, based on factors such as cost, availability, density, flame retardance, resistance to abrasion, aesthetics and cleanability.

3. Isolation mounts – Vibrating equipment creates sound pressure waves (noise) in the surrounding air. Anything that is physically connected to a generator set can cause vibrations to be transmitted to the building structure. These connection points include skid anchors, radiator discharge air ducts, exhaust piping, coolant piping, fuel lines and wiring conduit. Fitting these connections with flexible joints effectively reduces noise transmission. Mounting a generator set on spring-type vibration isolators effectively reduces the vibration and noise that are transmitted through the floor.

4. Cooling air attenuation – Inlet and outlet air attenuation baffles can help reduce the noise produced by the cooling air as it moves across the engine and through the radiator. Noise from the movement of cooling air is significant because of the volume required – about 20 cubic meters per second for a generator set with a 50-liter diesel engine. Alternatively, the radiator can be remotely located to a roof, for example, to eliminate this noise source or direct it up and away from people or the property line. Also, making air travel through a 90-degree bend in a duct reduces high-frequency noise. See Figure 6.

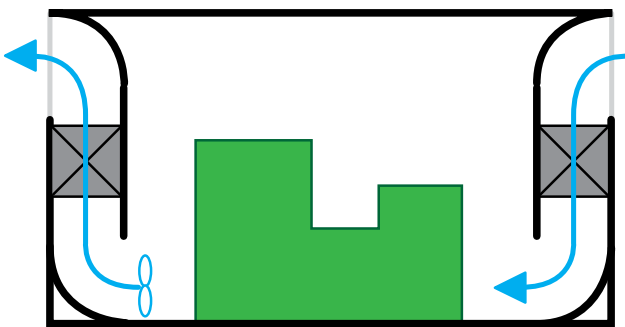

Figure 6: Reducing high-frequency noise by making the generator set cooling air turn 90 degrees several times as it enters or leaves a room or enclosure

5. Maximizing distance – When there are no reflecting walls to magnify the noise produced by the generator set, the noise level will decrease by approximately 6 dB(A) every time the distance is doubled (see Figure 7). If the property line is within the near field of a generator set, however, the noise level may not be predictable. A near-field environment is any location within twice the largest dimension of the noise source (generator set).

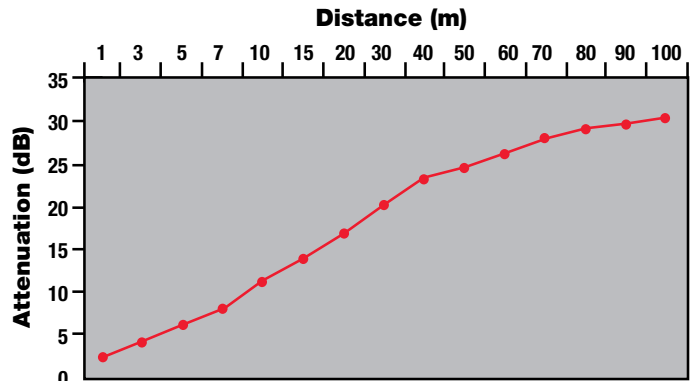

Figure 7: Reduction of sound over distance

6. Exhaust silencers – Generator sets are almost always equipped with an exhaust silencer (muffler) to limit exhaust noise from the machine. Exhaust silencers come in a wide variety of types, physical arrangements and materials. Silencers are generally grouped into either chamber-type silencers or spiral type devices. The chamber-type devices tend to be more effective, but the spiral-type devices are more compact and may provide sufficient attenuation for many applications. Silencers can be made of cold-rolled steel or stainless steel. Stainless steel is the preferred material for use outdoors when corrosion is a concern. Silencers are available in several different noise-attenuation “grades,” commonly referred to as “industrial,” “residential” and “critical.” Industrial silencers reduce noise from 12 to 18 dB(A); residential silencers reduce noise from 18 to 25 dB(A); critical silencers reduce noise from 25 to 35 dB(A). In general, the more effective a silencer is at reducing exhaust noise, the greater the level of restriction on the engine exhaust. For long exhaust systems, the piping itself will provide some level of attenuation.

About the author



Dennis Aaberg, senior acoustics specialist, has degrees in Electro-Mechanical Technology and Industrial Drafting and Technology from Alexandria Technical College. He has worked in the field of sound and

vibration engineering for Cummins Power Generation for the past 29 years. In that time, he has supported engineering and marketing departments with sound and vibration measurements and analysis, as well as design direction for all product lines produced at Cummins Power Generation in Fridley, Minnesota.

Sound-attenuating enclosures

Steel and aluminum enclosures of all kinds provide at least 10 dB(A) of attenuation for generator sets that must be located outdoors. In many cases, when combined with an effective exhaust silencer, this amount of attenuation may be sufficient to meet many local ordinances in North America and throughout Europe. Standard enclosures are available from most generator set manufacturers and from a variety of third-party providers.

When a greater amount of attenuation is needed to meet local noise ordinances or reduce impact on employees or neighbors, special sound-attenuating enclosures must be employed. In general, the cost of the enclosure is directly related to the level of sound attenuation required. In critical cases, it is not uncommon for the cost of the sound-attenuated enclosure to equal the cost of the generator set. Some enclosures also may negatively impact generator set performance by limiting proper ventilation and load-carrying capacity. Careful design from the outset is important to attain noise-control goals while maintaining generator set performance.

Special sound-attenuating enclosures combine both barrier and absorption noise control strategies to contain

generator set noise. While both steel and aluminum sound-attenuating enclosures are available, steel – because of its greater mass and stiffness – provides about 2-3 dB(A) better attenuation. Aluminum enclosures are usually only specified in coastal regions where their corrosion resistance is important in the salt air.

Conclusion

With maximum noise levels permitted at a property line that range from 52 dB(A) to 72 dB(A), depending on location and zoning, and untreated generator set noise levels that approach 100 dB(A) or more, it is clear that generator set noise mitigation is a subject of great importance. Furthermore, the high cost of retrofitting a site for noise reduction makes it imperative to assess noise performance requirements early in the on-site power system design stage. Working closely with local regulators, the generator set manufacturer, consulting engineer or acoustic specialist will allow you to achieve your project's sound-attenuation goals.

For additional technical support, please contact your local Cummins Power Generation distributor. To locate your distributor, visit www.cumminspower.com.

Our energy working for you.™

www.cumminspower.com

© 2007 Cummins Power Generation Inc. All rights reserved. Cummins Power Generation and Cummins are registered trademarks of Cummins Inc. "Our energy working for you." is a trademark of Cummins Power Generation. PT-7015 (11/07) CPG-593

