



**AGAPE WATER SOLUTIONS**

Providing pure water for a cleaner tomorrow...

# Power Plant Wastewater Treatment

Jeff Tate

March 12, 2015

# Agape Water Solutions, Inc.

- A Pennsylvania Corporation
- High purity water systems
  - Custom Engineering
  - Manufacturing
  - Service
  - Worldwide
- Business model predicated on providing the best combination of components to achieve the greatest value for our customers

# PRODUCT OFFERING

- System Design
  - Solidworks 3D Mechanical
  - Autocad 2D Electrical
- Manufacturing
  - UL Approved Panel Shop
  - ASME BPE Welding
    - Orbital Welding
    - Manual Welding
  - GF & Asahi Certified Welding
    - IR Welding
- Service
  - Start up
  - Maintenance

## Markets

**Power Generation**

**Pharmaceutical**

**Food and Beverage**

**Industrial**

**Laboratories**

**Water Treatment  
Companies (OEM)**

# Introduction to RO-EDI

1950's:

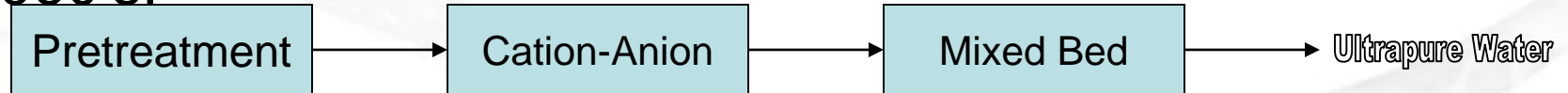

1980's:

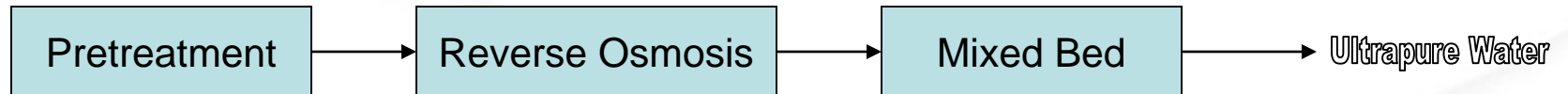

Late 1990's:



# RO Systems

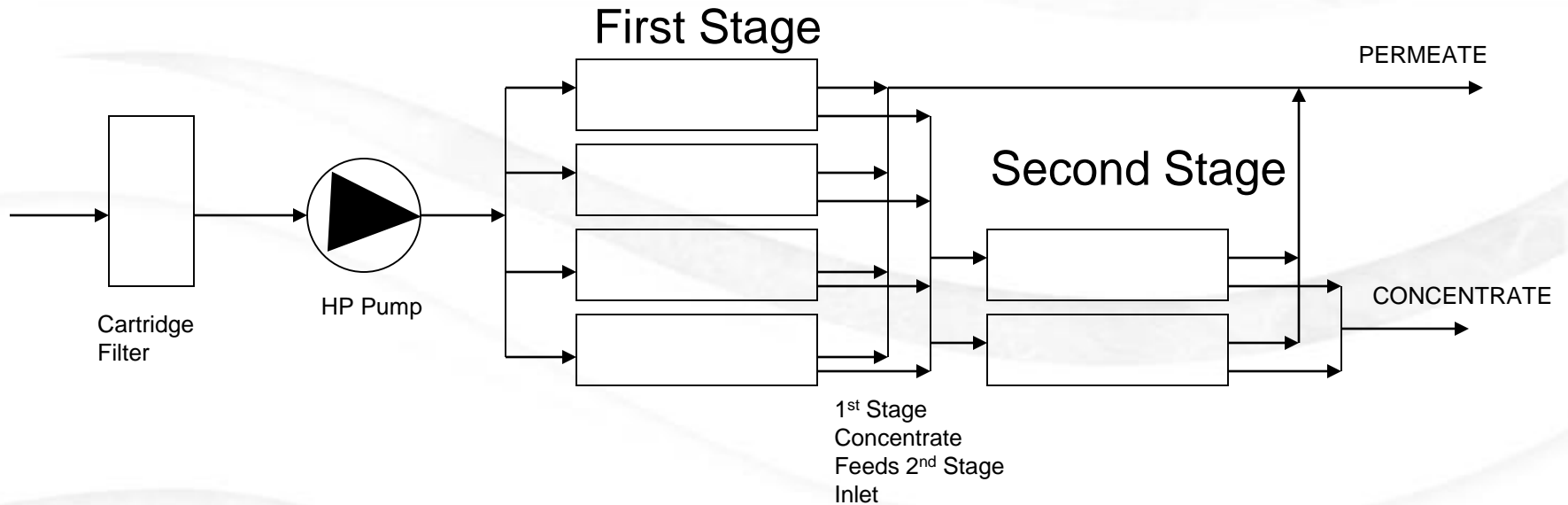

- Typical RO System operate at 50 to 75% recovery
- 25 to 50% Waste Water
- Special Designs can reduce recovery to 90% or higher

# EDI Systems

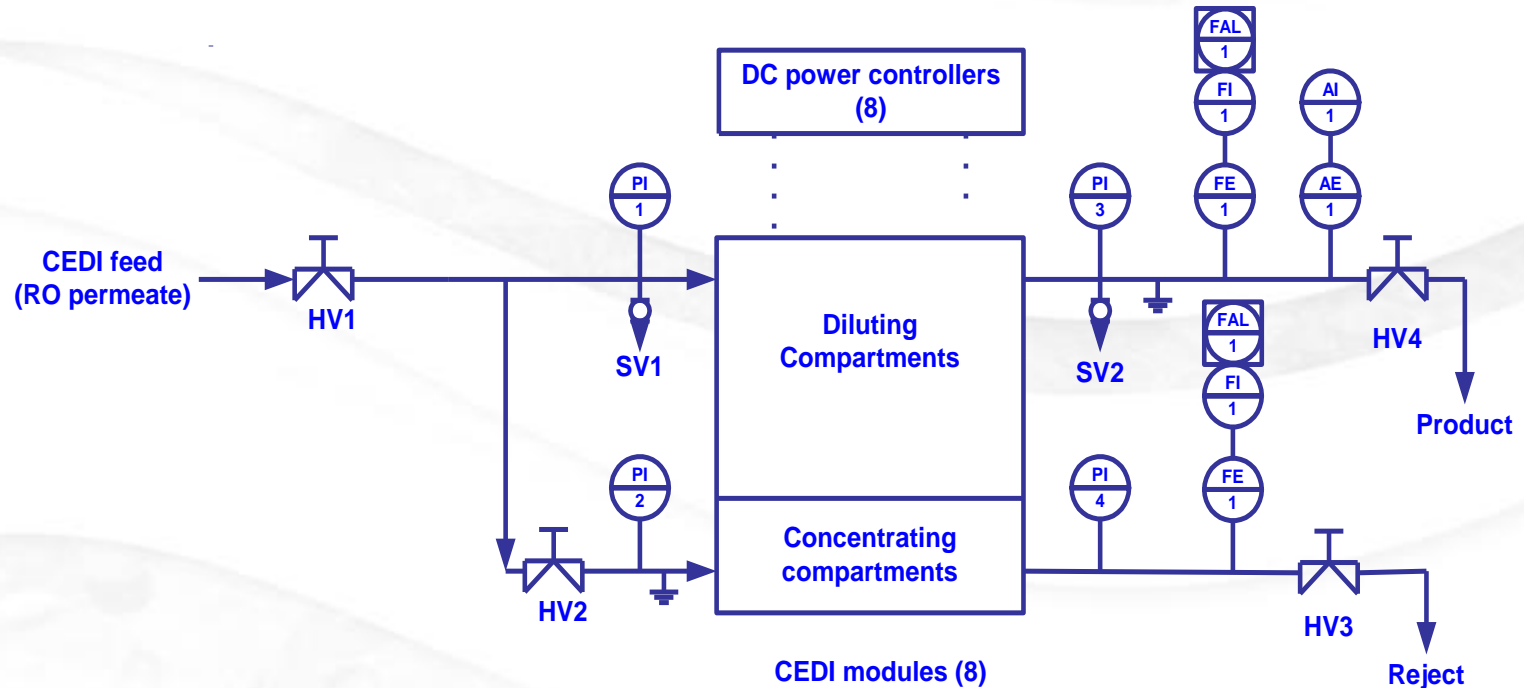

- Typical EDI Systems operate at 90 to 95% maximum recovery
- 5 to 10% Minimum Waste Water
- Special Designs can reduce recovery to 99%

# EDI Concentrate Recovery

- RO Salt Reject typically 95-99%
- EDI concentrate 10-20x RO permeate TDS (10-100% Feed TDS)
- EDI can be recovered to RO inlet via vented raw water storage tank
- Effectively 100% EDI recovery

\*Not including cleaning requirements

# Conclusions

- AGAPE WATER SOLUTIONS INC. PROVIDES SPECIFIC TECHNICAL SOLUTIONS TO OUR CUSTOMERS.
- REVERSE OSMOSIS AND ELECTRODEIONIZATION ARE EFFECTIVE CHEMICAL FREE TECHNOLOGIES.
- SPECIAL DESIGNS CAN REDUCE WASTE WATER TO 10% OR LOWER